



## 1 ton Electric Chain Hoist w/ Power Trolley 2 Speed 208~240V / 440~480V 3ph 60HZ

### Características Esenciales

- 3 Años de Garantía, Servicio y Atención al Cliente en Mexico

## Especificaciones Técnicas

Plug	Open Leads	Capacidad de Carga	1 ton
Altura de Izaje Estandar (Customizable)	20 ft / 6 m	Velocidad /min	1 st speed : (7.9 ft @60Hz - 2 mt @50Hz) / 2 nd speed : (25.59 ft @60Hz - 6.5 mt @50Hz)
Numero de Velocidades	2 Speed	Voltaje	3 Phase 208~240/480V 50/60Hz
Clase de Servicio	H4/M5/2m/Class D	Protección IEC Motor	IP55
Control	Pendant Control IP66	Voltaje del Control	24V
Tipo Transmisión / Reductor	Spur gearbox	Tipo de Cadena	G100 Nickel
Dimensiones de la Cadena	7.1 mm	Caidas de Cadena	1
Longitud de cadena	20	Humedad	20%~90%
Temperatura	-4 ~ 104° F / -20 ~ 40° C	Potencia del Trolley	500
Velocidad del Trolley /min	14.17~43.30 ft @60Hz 3.6~11 mt @50Hz	Cantidad de Velocidades	2
Rango de ancho de la Viga	2" to 6"	Radio Minimo de Giro	1.3
Normas	ASME HST-1 , ASME B30.16 , B30.17 , EN60204-33	Garantía	3 Year
Hoist Contactors Amps	18A	Hoist Contactor Brand	Schneider
Hoist Contactor Model	LC1D18B7C / LC1D188B7C	Hoist Contactor Coil Voltage	24 V
IEC Hoist IP Protection	IP55	Pendant Control Yes No	Yes
IEC Pendant Control Protection	IP66	Pendant Control Emergency Stop	Yes
Pendant Control total Length	17 ft	Hoist Motor Power in KW	1.5
Hoist Motor Brake Type and DC	DC90V/DC207V	Overload Protection	Overload Motor Clutch

Barium, Pigments

<b>Trolley Motor Brake Type and DC Voltage</b>	DC99V/DC207V	<b>Trolley Motor Insulation Grade</b>	F
<b>Trolley Contactors Amps</b>	32A	<b>Trolley Contactors Brand</b>	Schneider
<b>Trolley Contactors Model</b>	LC1D12B7C / LC1D128B7C	<b>Trolley Contactors Coil Voltage</b>	24 V
<b>Trolley Wheel Diameter</b>	95	<b>Trolley Wheel Material</b>	No. 45 steel
<b>Trolley Minimum Turn Radius</b>	1.3 m / 4.2 ft	<b>Trolley Beam Range</b>	2" to 6"
<b>Trolley Beam Extension Kit</b>	up to 12"	<b>Load Chain weight per foot [lbs]</b>	0.74
<b>1st Package Type</b>	Wood Crate	<b>2nd Package Type</b>	Wood Crate

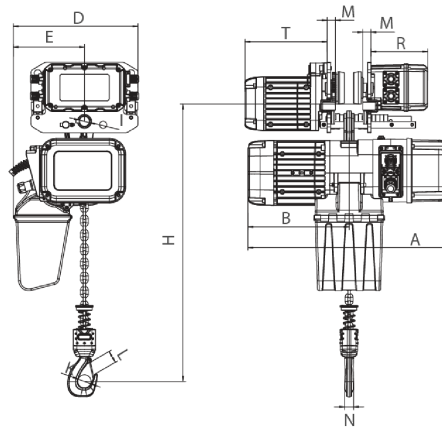

Rated load (t)	Type	Dimension (mm)												
		Minimum distance from the bottom of the track to the bottom hook: H	A	L	B	D	E	I	M	N	K	L	T	R
1	PWRXT1-01	473	440	3500-5500	285	210	20	105	140					
2	PWRXT2-01	516	590		276	368	210	31	24	25	42	32	242	167
3	PWRXT3-01	600	681		350	422	264	36	28	35	52	42	242	167
5	PWRXT5-02	645	681		350	478	307	43	30	34	59	48	242	167

## Peso & Dimensiones

**Peso Total** 244 lbs / 111 Kg

## Detalles del Empaque

**H Altura Muerta** 20.31

**A Altura Total** 20.31

**D Depth** 23.23

**W Ancho** 14.49

**J Boca Gancho** 1.65

**Peso Total (sin cable o cadena)** 190.22

Referential Images / Imágenes Referenciales  
Specifications may change without notice / las especificaciones pueden cambiar sin previo aviso