



3 ton Electric Chain Hoist w/ Power Trolley 1 Speed 208~240V / 440~480V 3ph 60HZ

Características Esenciales

- 3 Años de Garantía, Servicio y Atención al Cliente en Mexico

Especificaciones Técnicas

Plug	Open Leads	Capacidad de Carga	3 ton
Altura de Izaje Estandar (Customizable)	30 ft / 9 m	Velocidad /min	21.26 ft @60Hz 5.4 mt @50Hz
Numero de Velocidades	1 Speed	Voltaje	3 Phase 208~240/480V 50/60Hz
Clase de Servicio	H4/M5/2m/Class D	Protección IEC Motor	IP55
Control	Pendant Control IP66	Voltaje del Control	24V
Tipo Transmisión / Reductor	Spur gearbox	Tipo de Cadena	G100 Nickel
Dimensiones de la Cadena	11.2 mm	Caidas de Cadena	1
Longitud de cadena	30	Humedad	20%~90%
Temperatura	-4 ~ 104° F / -20 ~ 40° C	Potencia del Trolley	500
Velocidad del Trolley /min	43.30 ft @60Hz 11 mt @50Hz	Cantidad de Velocidades	1
Normas	ASME HST-1 , ASME B30.16 , B30.17 , EN60204-35	Garantía	3 Year
Hoist Contactors Amps	25A	Hoist Contactor Brand	Schneider
Hoist Contactor Model	LC1D25B7C	Hoist Contactor Coil Voltage	24 V
IEC Hoist IP Protection	IP55	Pendant Control Yes No	Yes
IEC Pendant Control Protection	IP66	Pendant Control Emergency Stop	Yes
Pendant Control total Length	27 ft	Hoist Motor Power in KW	3
Hoist Motor Brake Type and DC Voltage	DC99V/DC207V	Overload Protection	Overload Motor Clutch

Trolley Motor Brake Type and DC Voltage	DC99V/DC207V	Trolley Motor Insulation Grade	F
Trolley Contactors Amps	32A	Trolley Contactors Brand	Schneider
Trolley Contactors Model	LC1D12B7C	Trolley Contactors Coil Voltage	24 V
Trolley Wheel Diameter	124	Trolley Wheel Material	No. 45 steel
Trolley Minimum Turn Radius	1.6 m / 5.2 ft	Trolley Beam Range	3.9" to 7"
Trolley Beam Extension Kit	up to 12"	Load Chain weight per foot [lbs]	1.83
1st Package Type	Wood Crate	2nd Package Type	Wood Crate

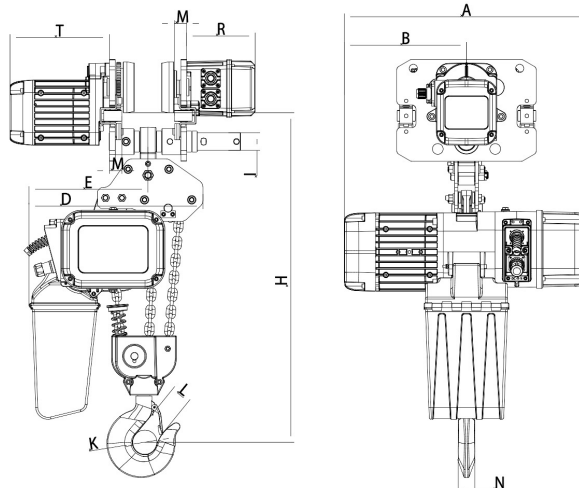

H	A	B	D	E	I	M	N	K	L	T	R
645	590	276	425	290	43	30	34	59	48	242	167

Peso & Dimensiones

Peso Total 417 lbs / 190 Kg

Detalles del Empaque

H Altura Muerta 25.39

A Altura Total 22.05

D Depth 27.36

W Ancho 16.54

J Boca Gancho 2.32

Peso Total (sin cable o cadena) 268.23

Referential Images / Imágenes Referenciales
 Specifications may change without notice / las especificaciones pueden cambiar sin previo aviso