

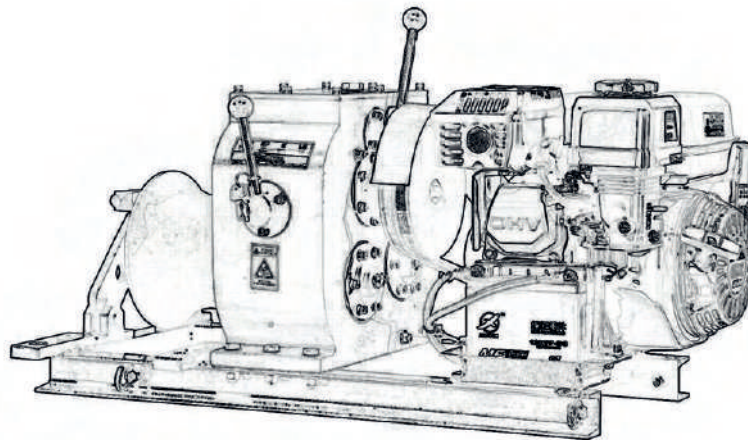

PWCD / PWCG Winches Series

User's Manual / Manual de usuario

Safety Warnings / Advertencias de Seguridad



PWC Series



PWCG3T



PWCG1Te

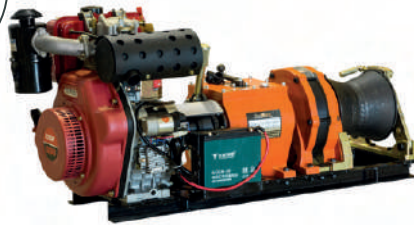

PWCD5T



PWCG120

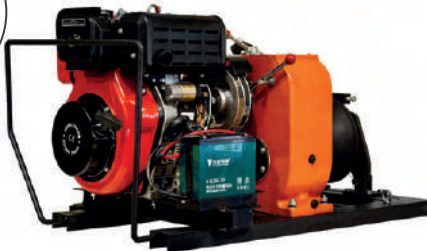
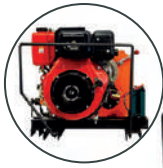

PWCD8Te

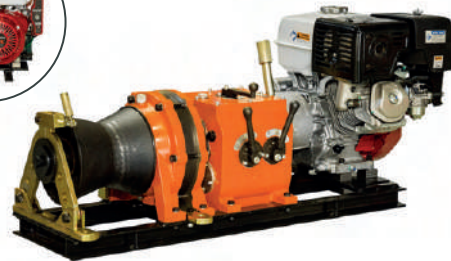

PWCG5T

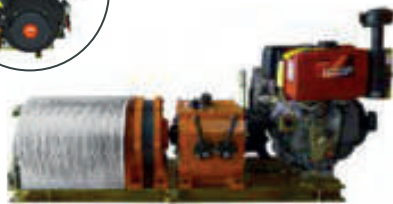

PWCD5TTM

| | |
|---------------------------------------|-----------|
| 1. PROWINCH® DISCLAIMER..... | 5 |
| 2. SAFETY PRECAUTIONS..... | 6 |
| General Precautions..... | 8 |
| Handling Precautions..... | 9 |
| General Enviromental Precautions..... | 11 |
| 3. SPECIFICATIONS..... | 12 |
| Unpacking..... | 12 |
| Installation..... | 12 |
| Mounting Solenoid Valve Assembly..... | 12 |
| Electrical Connections..... | 12 |
| Plumbing Connections..... | 13 |
| Cautions..... | 13 |
| 4 Speed Winch Operations..... | 14 |
| Procedure for winding the cable..... | 14 |
| Warranty..... | 17 |
| 5. HONDA ENGINE | 19 |
| 6. MITSUBISHI ENGINE | 45 |
| PWCD5T (Technical parameters)..... | 55 |
| PWCD5TTM (Technical parameters)..... | 56 |
| PWCG1T (Technical parameters)..... | 57 |
| PWCG3T (Technical parameters)..... | 58 |
| PWCG5T (Technical parameters)..... | 59 |
| PWCG120 (Technical parameters)..... | 60 |
| 7. MAPS PROWINCH® | 61 |

This page intentionally left blank

PROPERTY REGISTRY N° 189487
ANY REPRODUCTION IS FORBIDDEN
PROPERTY OF PROWINCH® 2025 - V.09.25 [XW]ALL RIGHTS RESERVED
PROWINCH LLC COMPANY WITH QUALITY MANAGEMENT SYSTEM

PROWINCH® DISCLAIMER

To view our full disclaimer, please visit www.prowinch.com/resource-center or scan the QR code below



Thank you for purchasing a Prowinch® winch. This manual describes the operation and maintenance of the winch. All information in this publication is based on the newest production information is available at print time.

2. SAFETY PRECAUTIONS

Prowinch's winches are designed to deliver a safe and trustworthy service if they are operated according to this manual. This manual contains essential information to help you properly install, operate and maintain your winch for maximum performance, economy, and safety. Please study its contents thoroughly before putting your winch into operation. You will experience long, dependable, and safe service by practicing correct operating procedures and following the recommended preventive maintenance suggestions. After thoroughly familiarizing yourself with the contents of this manual, we recommend that you carefully file it for future reference.

Applications for PWTR Prowinch® winches

Choose the Prowinch® winch that is right for you: PWTR series offers you, top-of-the-line models, from 9500 lbs up to 17000 lbs, featuring standard and optional accessories for recovery applications. We offer you lightweight, durable, and affordable winches. Specially designed for recovery applications, our winches are equipped with a durable wound motor for long life and extra pulling power, featuring a rugged 3-stage planetary gear box delivering power and reliability. The body and frame of your winch are corrosion-resistant stainless steel to provide a long life.

Mandatory use of:



Hard Hat



Safety Glasses



Safety Gloves



Safety Shoes



WARNING:

This symbol indicates unsafe practices or situations which may cause damage to the property and even injuries to the personnel.



DANGER:

This symbol indicates a potentially dangerous situation which if not avoided may cause severe injuries or death



DANGER

All operators and other users who are near the steel chain or its load must wear required safety equipment: gloves, safety helmet / hard hat, safety shoes and eye protection.



WARNING

Before installing, removing, inspecting, or performing any maintenance on the winche, the unit must be unplugged, locked out, and tagged out. Do not use this equipment in hazardous locations

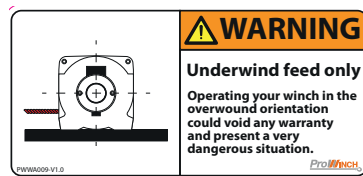
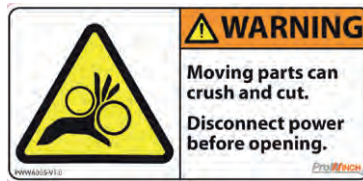

Read and understand the contents of this User Manual thoroughly before handling the product. Practicing correct and safe operating procedures and carrying out the recommended preventative maintenance will ensure a long, reliable, and safe service. After carefully reading and understanding the User Manual, store it for future reference.

2.1 GENERAL SAFETY PRECAUTIONS

- Take time to fully read the instructions from this User's Manual, in order to understand your winch and its operations.
- Do not exceed winch or winch wire rope rated capacity. Double line using a snatch block to reduce winch load.
- Do not use winch or winch wire rope for towing. Shock loads can damage, overload and break wire rope.
- Do not use a winch to secure a load.
- Do not operate this winch when under the influence of drugs, alcohol or medication
- Always wear heavy leather gloves and appropriate eye protection.
- Always remove jewelry.
- Always be aware of possible hot surfaces at winch motor, drum or wire rope during or after winch use.
- Inspect equipment regularly, replace damaged or worn parts, and keep appropriate records of maintenance.
- Only use PROWINCH®'s recommended parts for replacement. Any modifications or repairs without the approval of Prowinch will void the warranty.

2.1.1 SAFETY INSTALLATION

- Choose a mounting location that is sufficiently strong to withstand the maximum pulling capacity of your winch.
- Use class 8.8 metric (grade 5) or better hardware.
- Do not weld mounting bolts.
- Use factory approved mounting hardware, components, and accessories.
- Do not use bolts that are too long.
- Required bolt length to ensure proper thread engagement.
- Complete the winch installation and hook attachment before installing the wiring.
- Always keep hands clear of winch wire rope, hook loop, hook and fairlead opening during installation, operation, and when spooling in or out.
- Always position fairlead with warning readily visible on top.
- Prestretch wire rope and respool under load before use. Tightly wound wire rope reduces chances of binding, which can damage the wire rope.
- Insulate and protect all exposed wiring and electrical terminals.
- Do not route electrical cables across sharp edges, near parts that get hot and/or through or near moving parts.
- Always place the supplied terminal boots on wires and terminals as directed by the installation instructions.
- Do not lean over battery while making connections.
- Do not route electrical cables over battery terminals.
- Do not short battery terminals with metal objects.
- Battery Recommendations A fully charged conventional automotive battery with a minimum rating of 650 cold cranking amps is recommended to obtain peak performance from your winch. Make sure all electrical connections are clean and tight.
- Consult this User's Manual for proper wiring details.



DANGER:

Failure to observe these instructions could lead to serious injury or death.

2.1.2 SAFETY OPERATION

1. Inspect the winch wire rope, hook, and slings before operating the winch. You must replace frayed, kinked, or damaged winch wire rope immediately. You must replace damaged components before operation. Protect parts from damage.
2. Remove any element or obstacle that may interfere with the safe operation of the winch.
3. Always be sure the anchor you select will withstand the load and the strap will not slip.
4. Always use supplied hook straps whenever spooling winch wire rope in or out, during installation and operation.
5. Always require operators and bystanders to be aware of the vehicle and/or load.
6. Be aware of the vehicle's stability and load during winching; keep others away. Alert all bystanders of an unstable condition.
7. Always unspool as much winch wire rope as possible when rigging. Double line or pick a distant anchor point.
8. Take time to use appropriate rigging techniques for a winch pull.
9. Do not touch the winch wire rope or hook while someone else is at the control switch or during winching operation.
10. Do not engage or disengage the clutch if the winch is underload, the winch wire rope is in tension, or the drum is moving.
11. Do not touch the winch wire rope or hook while under tension or load.
12. Stand clear of winch wire rope and load and keep others away while winching.
13. Do not use a vehicle to pull the load on the winch wire rope. Combined or shock load can damage, overload, and break wire ropes.
14. Do not wrap the winch wire rope back onto itself. Use a choker chain or tree trunk protector on the anchor.
15. Do not operate the winch with less than 5 wraps of winch wire rope or 10 wraps of synthetic rope around the drum. Wire rope could come loose from the drum, as the wire rope attachment is not designed to hold a load.
16. Do not use the winch as a hoist or to suspend a load.
17. Always be sure the anchor will withstand the load, use appropriate rigging, and take time to rig correctly.
18. Do not use the winch to lift or move persons.
19. Do not use excessive effort to free spool winch wire rope.
20. Always use proper lifting techniques or get lifting assistance while handling and installing.
21. Always wind the winch wire rope on the bottom (mountside) of the drum.
22. Do not wind wire rope over the top of the drum. Always spool the winch wire rope onto the drum in the direction in this manual.
23. Do not leave the remote control where it can be activated during free spooling, rigging, or when the winch is not being used.
24. Do not leave the winch remote control plugged in when installing, freespooling, rigging, servicing or when the winch is not being used.
25. Do not operate any equipment on which the safety placards or decals are missing or illegible.
26. Report any malfunction or irregular operation of the equipment.
27. Do not operate equipment that has been modified without previous PROWINCH® approval.
28. Winch damper helps to prevent wire rope recoil in the event of a wire rope failure. Do not approach or move the damper once tension is applied. Do not allow it to get pulled into the fairlead.



1. Do not exceed winch or winch rope rated capacity.

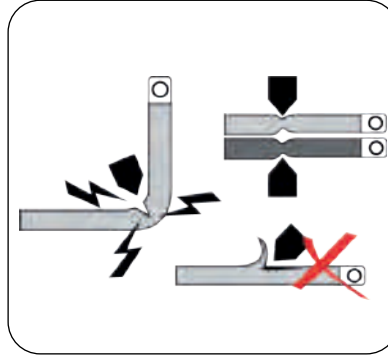

2. Do not route electrical cables across sharp edges, near parts that get hot and/ or through or near moving parts.

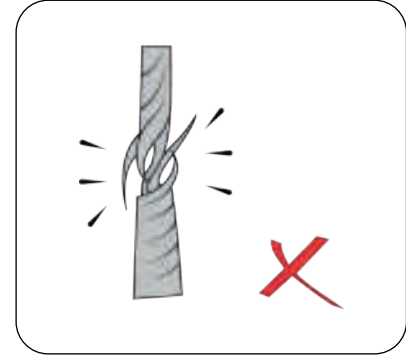

3. Always inspect winch rope, hook, and slings before operating winch. Frayed, kinked or damaged winch rope must be replaced immediately.

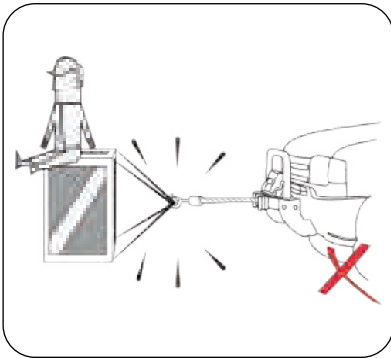

4. Do not use the equipment to lift or move people.

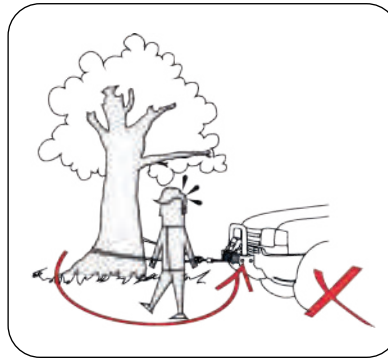

5. During winching operation always be aware of stability of vehicle and load during winching, keep others away. Alert all bystanders of an unstable condition.



6. Do not submerge winch in water. Always store the remote control in a protected, clean, dry area.

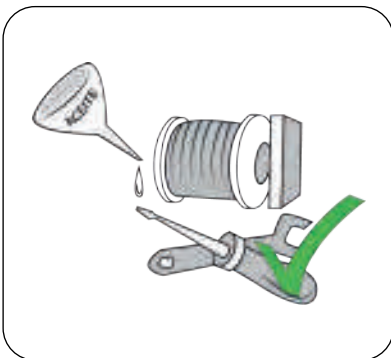

7. Perform preventive checks as part of a regular maintenance schedule to keep your winch operating properly.

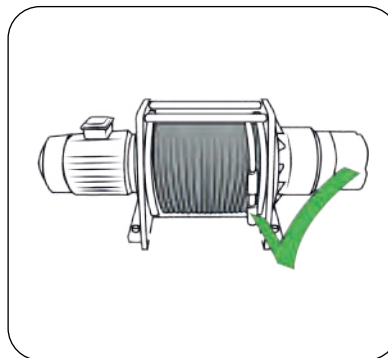

8. Always verify installation before operating.

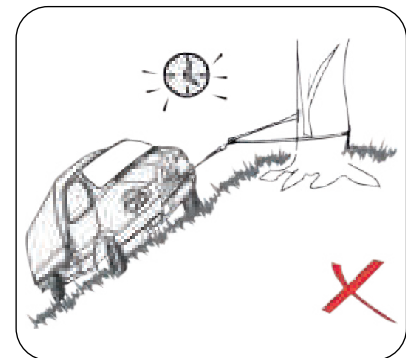

9. Do not leave loads unattended, wire rope could come loose from the drum, as the wire rope attachment to the drum is not designed to hold a load.

2.1.3. GENERAL ENVIROMENTAL PRECAUTIONS



DANGER:

The following environmental conditions can cause malfunction of the winch.

The following environmental conditions may cause malfunctions in the equipment. When operated outdoor, a shelter should be used for extreme weather conditions: below -10°C or above 40°C

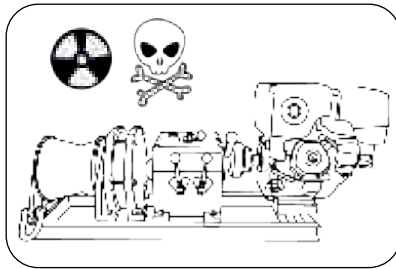

If used near chemicals, corrosive gas or explosives may cause an explosion.
Exposure to salt or acids may cause malfunctioning.

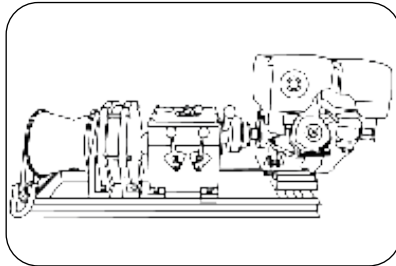

Exposure to sand may cause malfunctioning.

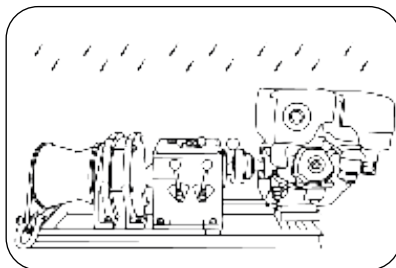

Avoid exposure to rain or snow. It may cause rusting of the equipment.

WARNINGS



3. SPECIFICATIONS

3.1 Unpacking

When unpacking, check to make sure all parts are included. Refer to Winch Assembly Drawing and Parts List (both with respective item numbers) at the end of this manual.

3.2 Installation

Mount winch to the vehicle by using high strength cap screw. It should be aligned and secured to a solid part of the vehicle (front or rear) where the full rated load will be evenly distributed.

3.3 Mounting the directional solenoid valve assembly(Optional)

The valve should be mounted away from any areas where heat may be considered too extreme. Such as an exhaust manifold or turbo. Be sure all plumbing and wiring reach the area selected without being stressed. It may be mounted by using the bracket and Allen screws supplied. Using the bracket as a guide, mark where the mounting holes will be drilled, remove the plate, and drill four 1/4" holes. Mount valve assembly using nuts, and bolts. Note: There is no need to mount a directional solenoid valve if there is already one manual directional valve on the vehicle.

3.4 Electrical connections

If the winch's power supply is from the vehicle's existing power steering pump, the solenoid valve system is designed to default to the power steering box, so power steering is always available even when the winch is in use. The power source to the solenoid is not energized until the three-pole quick connector plug is plugged in. Each solenoid has two wires--either of which can be used as a ground or for electric power. The grounds are connected at the factory. The other will connect to the blue and yellow wire in the harness (see illustration). Determine a location on the front grill to mount the female 3-pole plug connector. Drill a hole and mount the female 3-pole plug connector using nuts, bolts and washers supplied. Connect all wiring as shown in the illustration. Test hand control unit; solenoids will make a slight "click" sound if connected properly. Note: There is no need to do the wiring if there is already one manual directional valve on the vehicle.

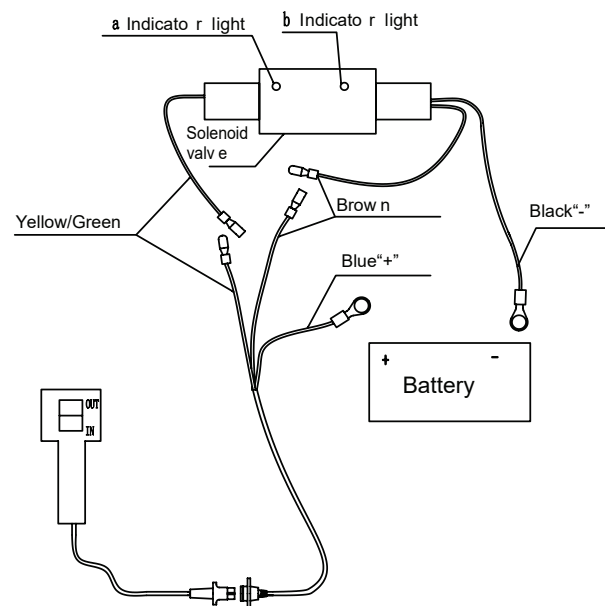

3.5 Plumbing connections

Keep all hoses away from areas where heat may be considered too extreme such as an exhaust manifold or turbo. Lines should not be allowed to rub on any abrasive or vibrating surfaces. In some applications, right-angle fittings on the directional and motor or balance valves are necessary to make hose mounting more flexible. After plumbing has been laid out on the vehicle, install o-ring fittings supplied to valve. Torque tight. **DO NOT OVERTIGHTEN ANY FITTINGS.** Install o-ring fittings on the winch motor. Torque tight. Connect any hose port A on the motor or port C1 on the balance valve to port A on the directional valve, port B on the motor or port C2 on the balance valve to port B on the directional valve, port P on the directional valve to pump's high-pressure port, port T on the valve to the reservoir. Attach any o-ring or seal from the vehicle's original tube fitting to the tube fitting.

3.6 Cautions

Battery cables should not be drawn stretched to limit. Leave slack for some cable movement. If your application is supplied with an added cooler, please check and follow the steps.

1. Check fluid level.
2. Replace lost fluid to system.(System will need to be purged).
3. Start engine. (Power winch cable in 5 feet).
4. Shut engine off.
5. Check fluid level. (Add fluid until full, start engine, power winch cable, Out 5 feet, Shut engine off and Check
6. fluid level.) Add fluid until full if necessary.
7. Start engine. Power winch cable into desired position. Turn vehicle wheels from lock to lock position 5 times.
8. This will aid in bleeding out any air that may have got into the system.



WARNING

Make sure the clutch is totally engaged before starting any winch operation.
Stay clear and away from raised loads.
Stay clear of cable while pulling do not try to guide cable.
A min. of wraps of cable around the drum.

3.7 Procedures to winding the cable

1. Wind the cable around the drum by opening the side of the adjustable frame with a wrench.
2. Ways to wind the cable: from the bottom and up, both ends of the cable come out through the lower side of the winch giving 5 to 6 turns minimum of it, one towards where it is the load and the other next to the operator's assistant, who holds the cable tightly and guides it pulling or delivering according to the direction of operation.
3. The winch has pulling capabilities with the engine running slow and fast, adjust the acceleration according to demand.
4. Make sure that everyone is clear of the Winch cable during the stages of work, 1.5 times the length of the cable is recommended. If a cable becomes loose or breaks under the charging can produce a whiplash causing serious injury or even death.
5. NEVER unhook the winch lock when there is a load.

4. Speed Winch Operations



PWCG3T Lever Instructions Diagram

DE
RELEASE

E
COUPLING

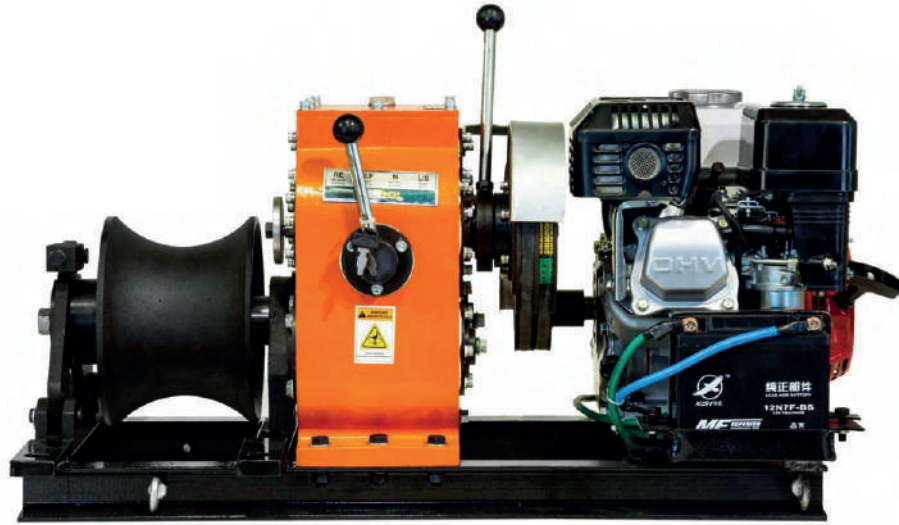

RE **F** **N** **S**
REVERSE FAST NEUTRAL SLOW

F **S**
FAST SLOW

PWCD5T y PWCG5T Lever Instructions Diagram

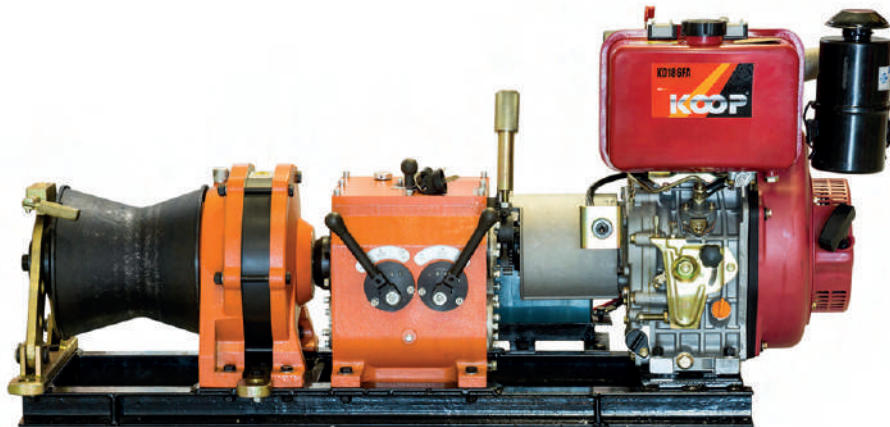

DE
RELEASE

E
COUPLING

RE **F** **N** **S**
REVERSE FAST NEUTRAL SLOW

| PARAMETERS | GEARBOX | | |
|-----------------|---------|------|------|
| | I | | II |
| | FAST | SLOW | FAST |
| Capacity (Ton) | 2,5 | 5 | 0,9 |
| Velocity (m/mm) | 8 | 4 | 24 |

PWCG120 Lever Instructions Diagram

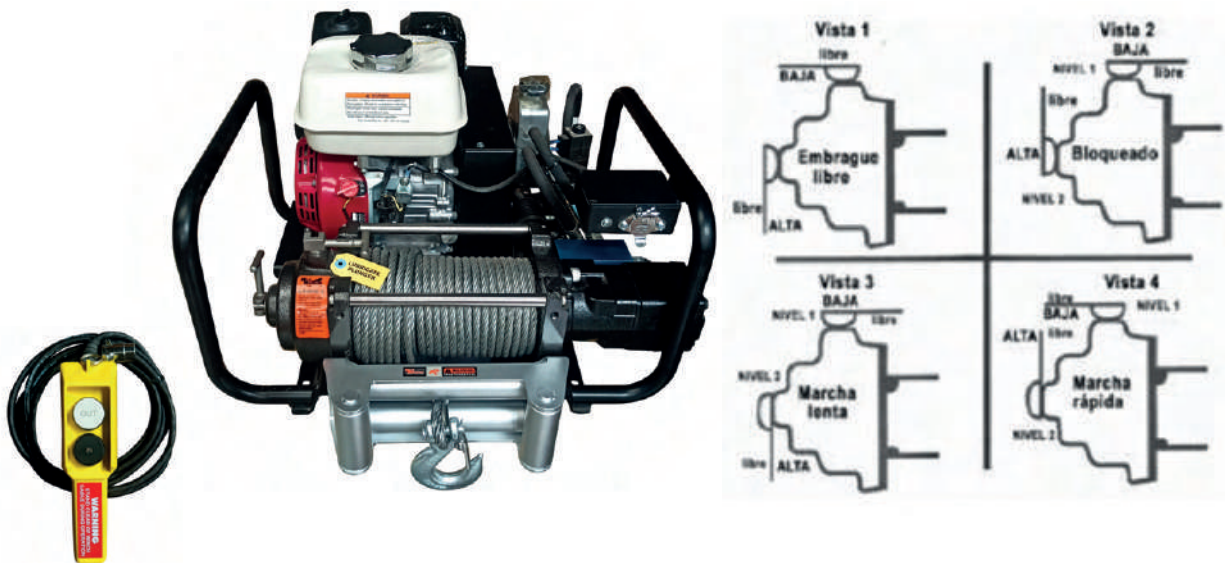

5. MAINTENANCE OF THE WINCH

It is recommended that the winch be used regularly to maintain the lubrication of all internal parts. This ensures that all components are in good condition so you can trust the winch when needed. Contact Prowinch® for technical assistance, spare parts, and repairs.

After being inactive for more than 6 months and ensuring the winch's proper functioning, careful examination and inspection by operators trained in maintenance will be necessary. Keep the winch clean in a dry place, free from dust and / or harmful pollutants, and a temperature between 32 degrees F and 104 degrees F.

WARNING



Make sure the clutch is totally engaged before starting any winch operation.
 Stay clear and away from raised loads.
 Stay clear of cable while pulling do not try to guide cable.
 A min. of wraps of cable around the drum.

Prowinch® Warranty

To view our full warranty policy, please visit www.prowinch.com/resource-center or scan the QR code below



ENGINE SAFETY

1. Honda engines are designed to give safe and dependable service if operated according to instructions. Read and understand this Owner's Manual before operating the engine. Failure to do so could result in personal injury or equipment damage.
2. To prevent fire hazards and to provide adequate ventilation, keep the engine at least 1 meter (3 feet) away from buildings and other equipment during operation. Do not place flammable objects close to the engine.
3. Children and pets must be kept away from the area of operation due to the possibility of burns from hot engine components or injury from any equipment the engine may be used to operate.
4. Know how to stop the engine quickly, and understand the operation of all controls. Only permit people to operate the engine with proper instructions.
5. Gasoline is highly flammable and is explosive under certain conditions.
6. Refuel in a well-ventilated area with the engine stopped. Do not smoke or allow flames or sparks in the refueling area or where gasoline is stored.
7. Do not overfill the fuel tank. After refueling, make sure the tank cap is closed properly and securely.
8. Be careful not to spill fuel when refueling. Fuel vapor or spilled fuel may ignite. If any fuel is spilled, make sure the area is dry before starting the engine.
9. Never run the engine in an enclosed or confined area. The exhaust contains poisonous carbon monoxide gas; exposure may cause loss of consciousness and may lead to death.
10. The muffler becomes very hot during operation and remains hot after stopping the engine. Be careful not to touch the muffler while it is hot. To avoid severe burns or fire hazards, let the engine cool before transporting or storing it indoors.

Read these labels before you operate the engine.

GASOLINE WARNING LABEL

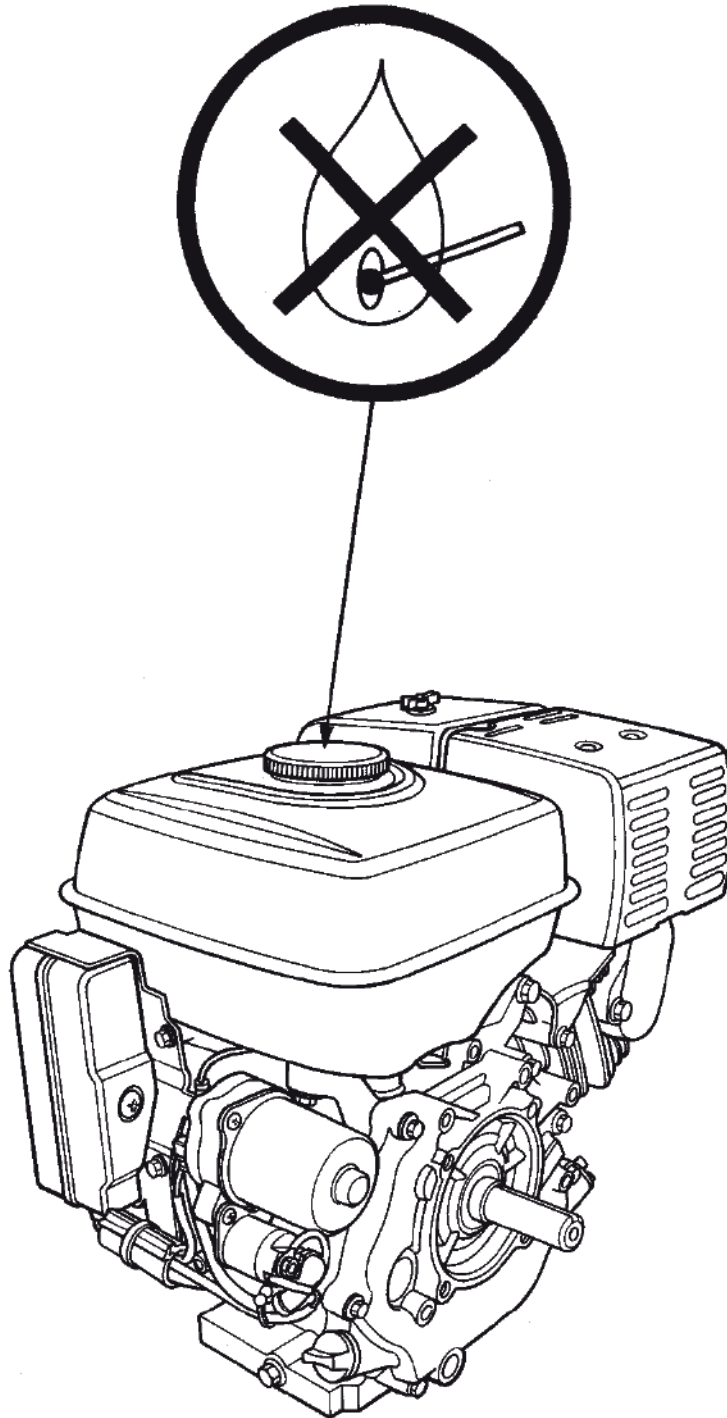

COMPONENT IDENTIFICATION

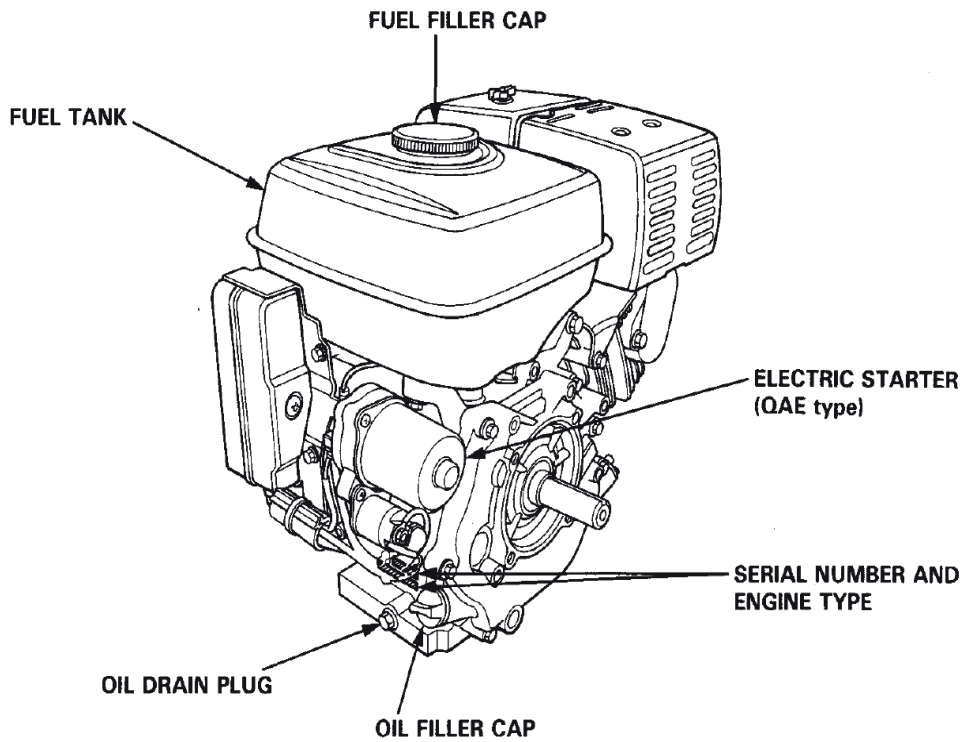
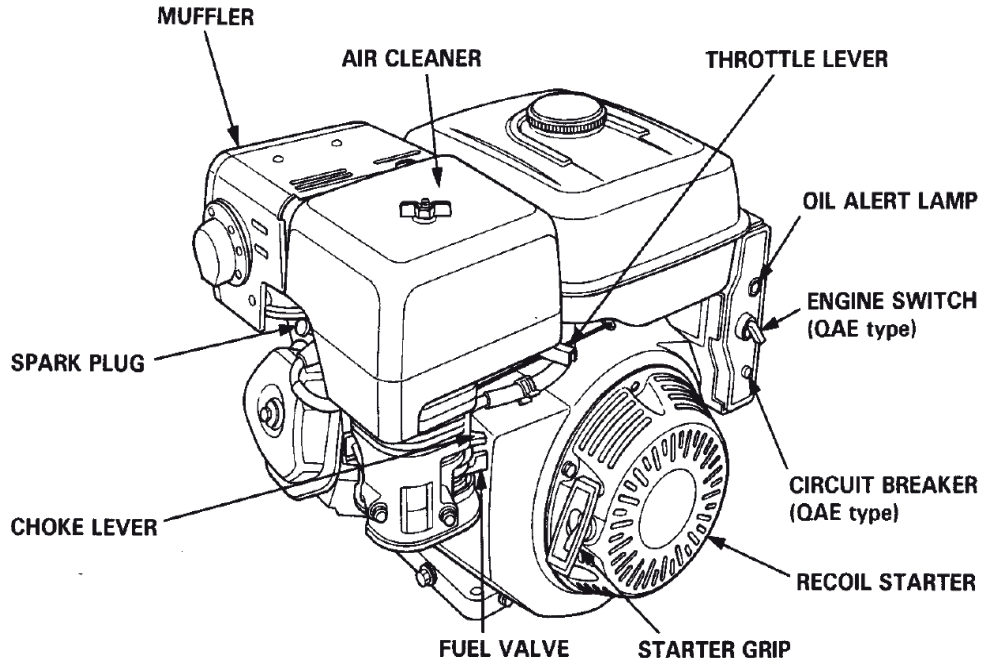

BATTERY CONNECTIONS (QAE TYPE)

- Use a 12 volt battery with an ampere-hour rating of at least 18 AH.
- Connect the battery positive (+) cable to the starter solenoid terminal, as shown.
- Connect the battery negative (-) cable to an engine mounting bolt, frame bolt, or other good engine ground connection.
- Check the battery cable connections to be sure the cables are tightened and free of corrosion. Remove any corrosion and coat the terminals and cable ends with grease.

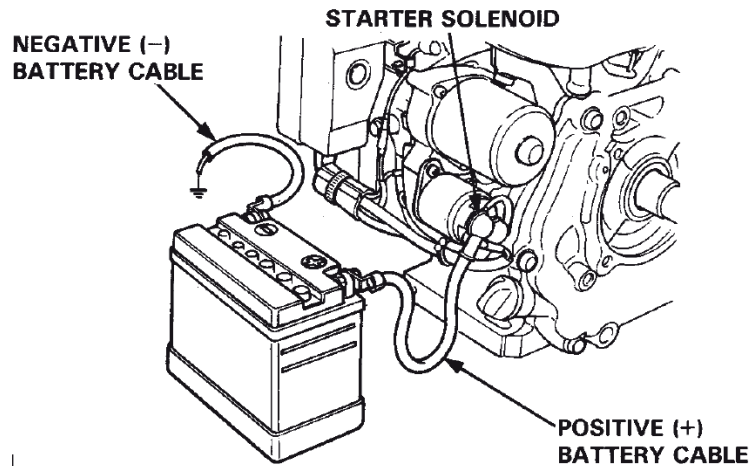

WARNINGS

Use a 12-volt battery with an ampere-hour rating of at least 18 AH. Connect the battery positive (+) cable to the starter solenoid terminal, as shown. Connect the battery negative (-) cable to an engine mounting bolt, frame bolt, or other good engine ground connection. Check the battery cable connections to be sure the cables are tightened and free of corrosion. Remove any corrosion and coat the terminals and cable ends with grease.

- The battery emits explosive gases; keep sparks, flames, and cigarettes away. Provide adequate ventilation when charging or using batteries in an enclosed space.
- The battery contains sulfuric acid (electrolyte). Contact with skin or eyes may cause severe burns. Wear protective clothing and a face shield.
- If electrolyte gets on your skin, flush with water.
- If electrolyte gets in your eyes, flush with water for at least 15 minutes and call a physician immediately.
- Electrolyte is poisonous. (If swallowed, drink large quantities of water or milk, follow with milk of magnesia or vegetable oil, and call a physician).
- KEEP OUT OF REACH OF CHILDREN.

NOTICE

Use only distilled water in the battery. Tap water will shorten the service life of the battery.

- Filling the battery above the UPPER-LEVEL line may cause the electrolyte to overflow, resulting in corrosion to the engine or nearby parts. Immediately wash off any spilled electrolytes.
- Be careful not to connect the battery in reverse polarity, as this will short-circuit the battery charging system and trip the circuit breaker or fuse.

REMOTE CONTROL LINKAGE

For throttle and choke cables

The throttle and choke control levers are provided with holes for optional cable attachment. The following illustrations show installation examples for a solid wire cable and for a braided wire cable. If using a braided wire cable, add a return spring as shown.

It is necessary to loosen the throttle lever friction nut when operating the throttle with a remote cable.

[Remote throttle]

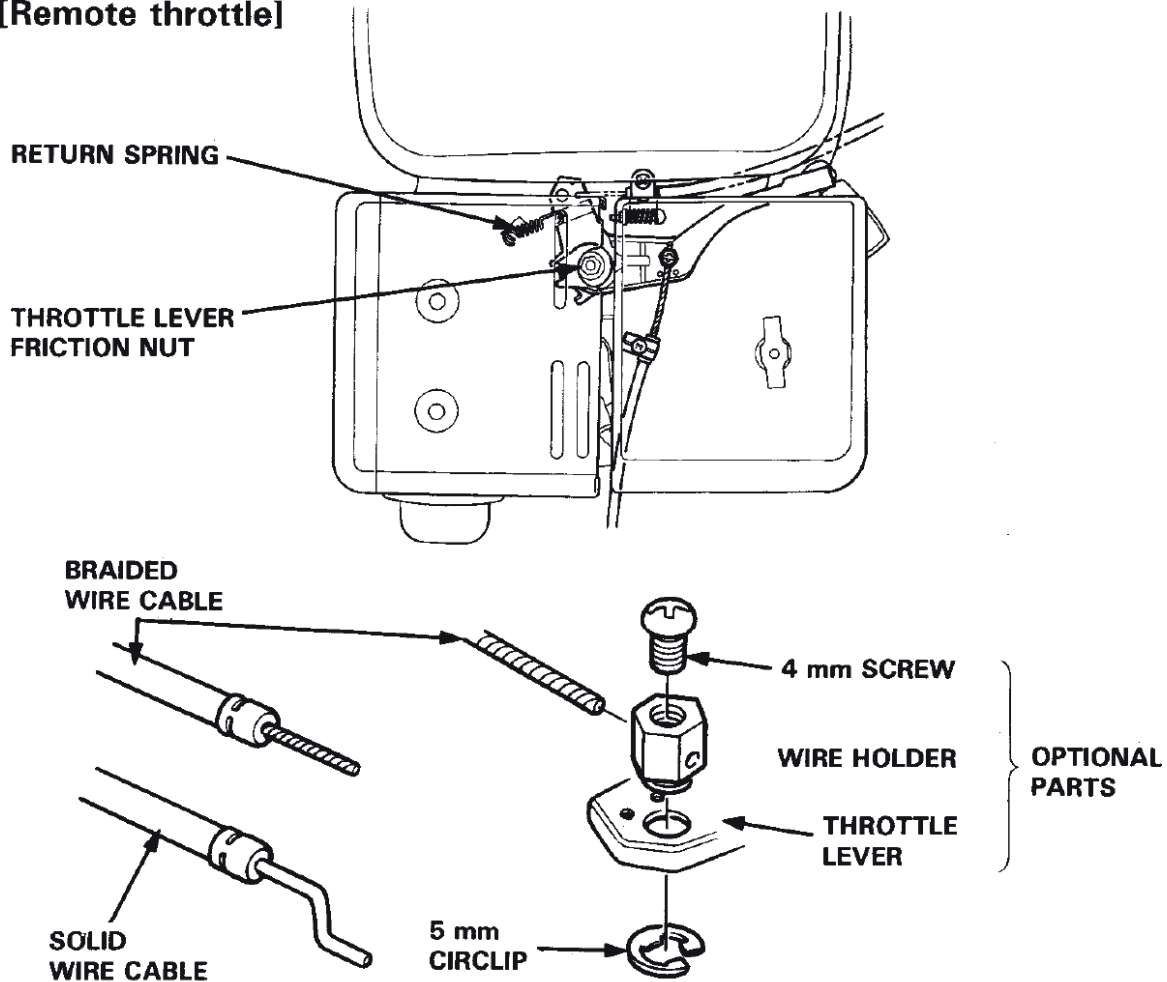

[Remote choke]

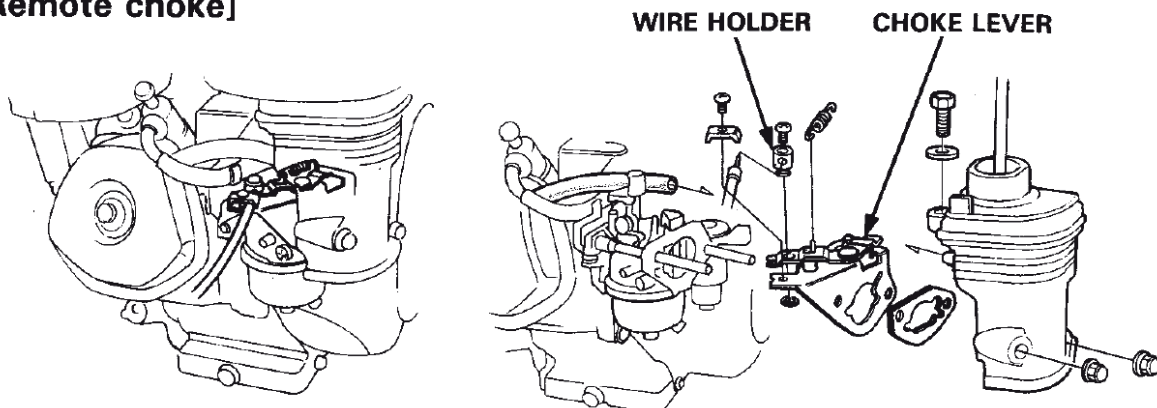

PRE-OPERATION CHECK

NOTICE 1. ENGINE OIL

Engine oil is a significant factor affecting engine performance and service life. Nondetergent and 2-stroke engine oils are not recommended because they have inadequate lubricating characteristics. Check the engine on a level surface with the engine stopped.

Use Honda 4-stroke oil or an equivalent high-detergent, premium quality motor oil certified to meet or exceed U.S. automobile manufacturer's requirements for Service Classification SG-SF/ CC-CD. (Motor oils classified SG-SF/CC-CD will show this designation on the container.)

1. Remove the oil filler cap and wipe the dipstick clean.
2. Insert the dipstick into the oil filler neck, but do not screw it in.
3. If the level is low, fill to the top of the oil filler neck with the recommended oil.

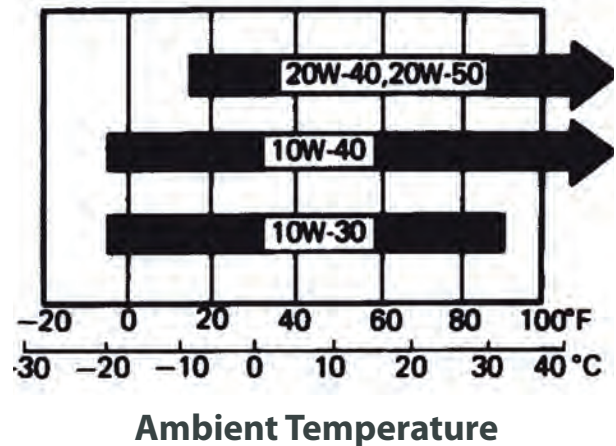

NOTE

The oil Alert System will automatically stop the engine before the oil level falls below the safe limit. However, to avoid the inconvenience of an unexpected shutdown, it is advisable to inspect the oil level regularly visually.

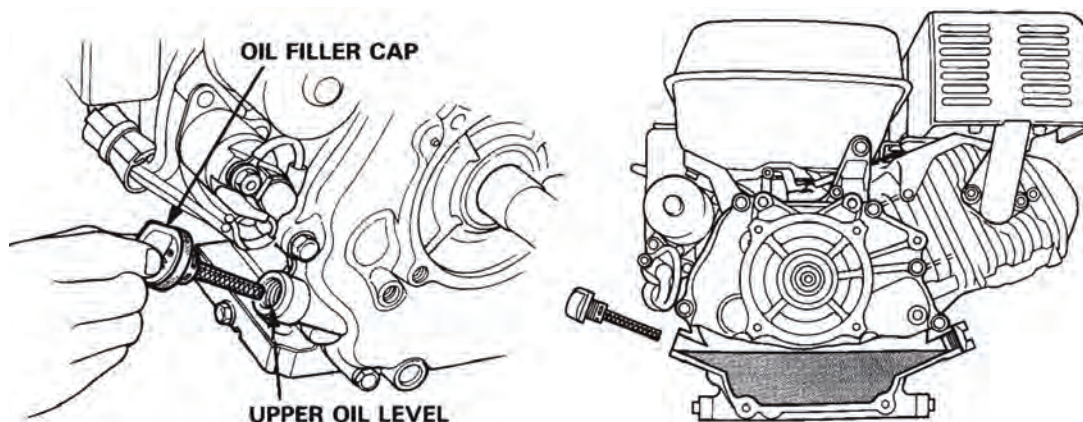

PRE-OPERATION CHECK

<1/2 reduction with automatic centrifugal clutch>

1. Remove the oil filler cap and wipe the dipstick clean.
2. Insert the dipstick into the filler neck, but do not screw it in.
3. If the level is low, fill to the upper level mark with the same oil that is recommended for the engine (see engine oil recommendations on page 8).

Oil capacity: 300 cc (10 US oz, 8.4 Imp oz)

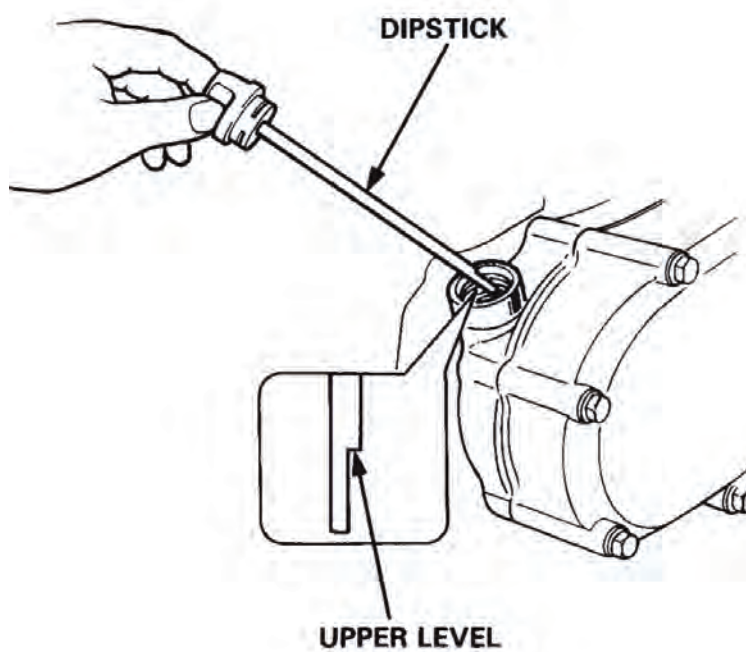

**AIR CLEANER
NOTICE**

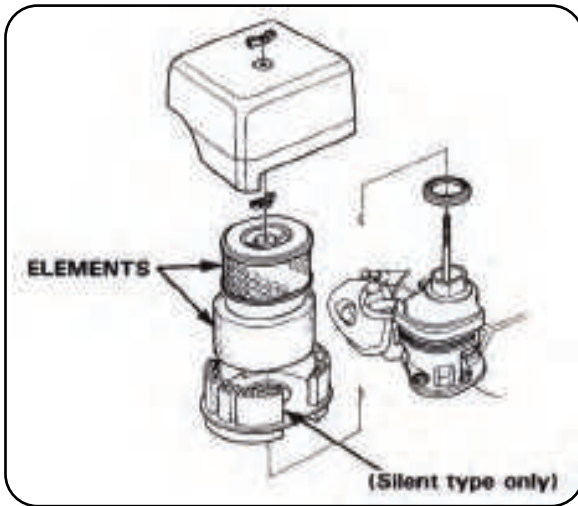

Never run the engine without the air cleaner. Rapid engine wear will result from contaminants, such as dust and dirt, being drawn through the carburetor and into the engine.

<Dual element type>

Check the air cleaner elements to be sure they are clean and in good condition. Clean or replace the elements if necessary (p.21).

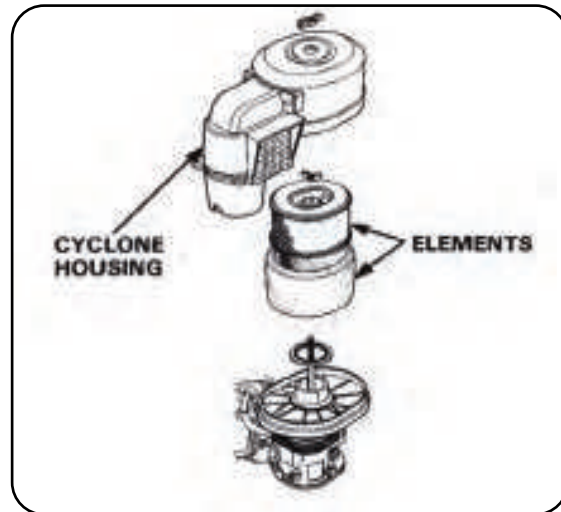

1. Check the air cleaner element to be sure they are clean and in good condition.
2. Clean or replace the elements if necessary (p.22).
3. Check the cyclone housing, and clean it if it is clogged or excessively dirty (p.22).

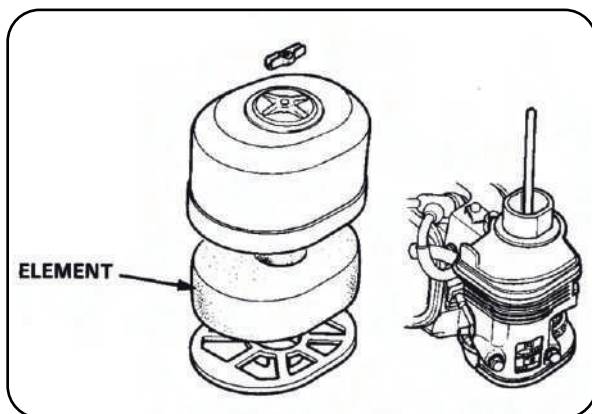

Check the air cleaner element to be sure it is clean and in good condition. Clean or replace the element if necessary (p. 23) .

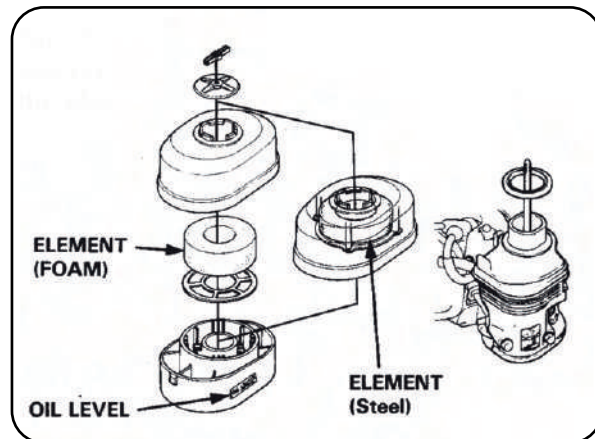

1. Check the air cleaner element to be sure it is clean and in good condition. Clean or replace the element if necessary (p.23).
2. Check oil level and condition.

FUEL

Your engine is designed to use gasoline with a pump octane number (R + M) of 86 or higher or a research octane number of 91 or higher. Gasoline pumps at the service station normally display the pump octane number.

We recommend that you use unleaded fuel because it produces fewer engine and spark plug deposits and extends the life of exhaust system components.

Never use stale or contaminated gasoline or an oil/gasoline mixture. Avoid getting dirt, dust, or water in the fuel tank. Use of lower-octane gasoline can cause persistent "pinging" or heavy "spark knock" (a metallic rapping noise), which, if severe, can lead to engine damage.

NOTICE

If "spark knock" or "pinging" occurs at a steady engine speed under normal load, change brands of gasoline. If spark knock or pinging persists, consult your authorized Honda dealer. Failure to do so is considered misuse, and Honda's Limited Warranty does not cover damage caused by misuse. Occasionally you may experience a light spark knock while operating under heavy loads. This is no cause for concern, it simply means your engine is running efficiently.



WARNINGS

- Gasoline is extremely flammable and is explosive under certain conditions.
- Refuel in a well-ventilated area with the engine stopped. Do not smoke or allow flames or sparks in the area where the engine is refueled or where gasoline is stored.
- Do not overfill the fuel tank (there should be no fuel in the filler neck). After refueling, make sure the tank cap is closed properly and securely.
- Be careful not to spill fuel when refueling. Spilled fuel or fuel vapor may ignite. If any fuel is spilled, make sure the area is dry before starting the engine.
- Avoid repeated or prolonged contact with skin or breathing of vapor. KEEP OUT OF REACH OF CHILDREN.
- Fuel tank capacity: GX240 • GX270 5.9 f (1.6 US Gal, 10.4 Imp pt)
GX340 • GX390 6.5 f (1.7 US Gal, 11.4 Imp pt)

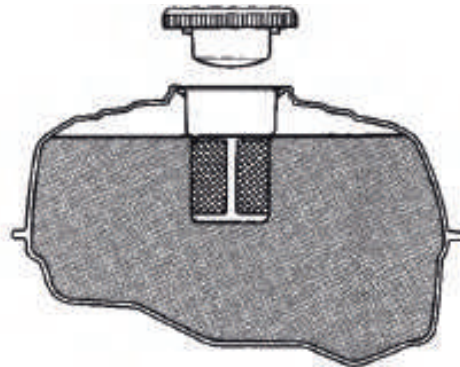
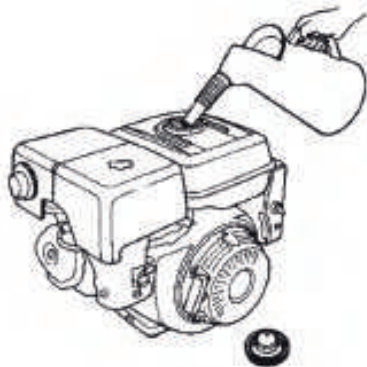

GASOLINE CONTAINING ALCOHOL

If you decide to use a gasoline containing alcohol (gasohol), be sure its octane rating is at least as high as that recommended by Honda. There are two types of "gasohol": one containing ethanol, and the other containing methanol. Do not use gasohol that contains more than 10% ethanol. Do not use gasoline containing methanol (methyl or wood alcohol) that does not also contain cosolvents and corrosion inhibitors for methanol.

Never use gasoline containing more than 5% methanol, even if it has cosolvents and corrosion inhibitors

NOTE

- Fuel system damage or engine performance problems resulting from the use of fuels that contain alcohol is not covered under the warranty. Honda cannot endorse the use of fuels containing methanol since evidence of their suitability is as yet incomplete.
- Before buying fuel from an unfamiliar station, try to find out if the fuel contains alcohol, if it does, confirm the type and percentage of alcohol used. If you notice any undesirable operating symptoms while using a gasoline that contains alcohol, or one that you think contains alcohol, switch to a gasoline that you know does not contain alcohol

STARTING THE ENGINE

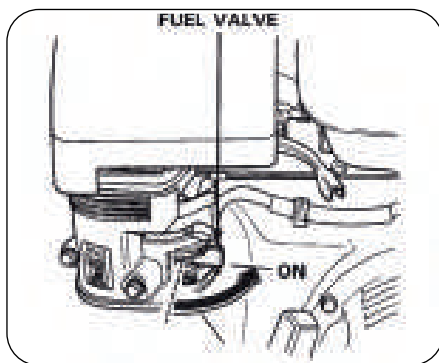

1. Turn the fuel valve to the ON Position

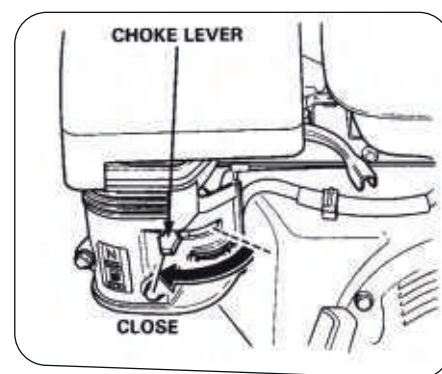

2. Move the choke lever to the CLOSE position

NOTE: The choke may not be needed if the engine is warm or the air temperature is high.

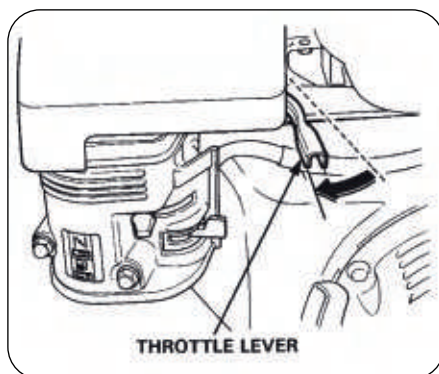

3. Move the throttle lever slightly to the left.

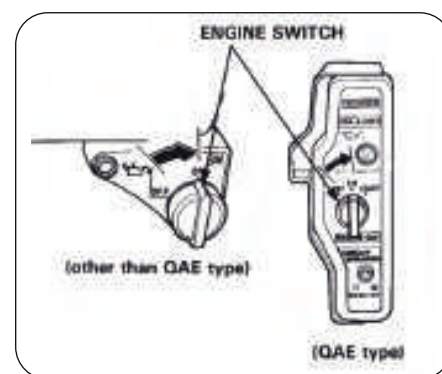

4. Start the engine. With recoil starter. Turn the engine switch to the ON position.

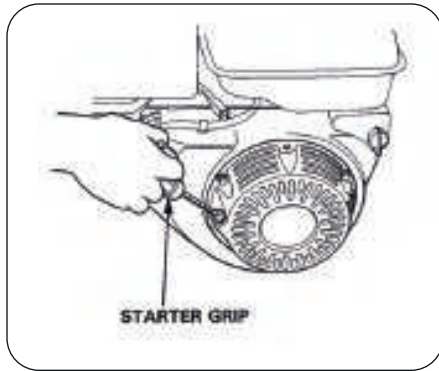

Pull the starter grip lightly until resistance is felt, then pull briskly.

NOTICE Do not allow the starter grip to snap back against the engine.

Return it gently to prevent damage to the starter

With electric starter (OAE type): Turn the engine switch to the START position and hold it there until the engine starts.

NOTICE

Do not use the electric starter for more than 5 seconds or starter motor damage may occur. If the engine falls to start, release the switch and wait 10 seconds before operating the starter again.

When the engine starts, allow the engine switch to return to the ON position.

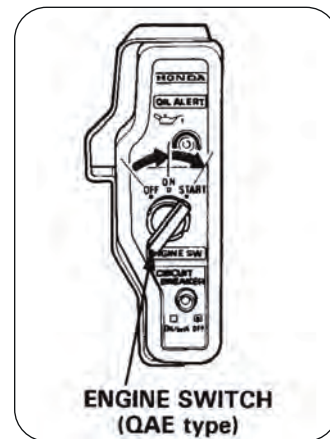

OPERATION

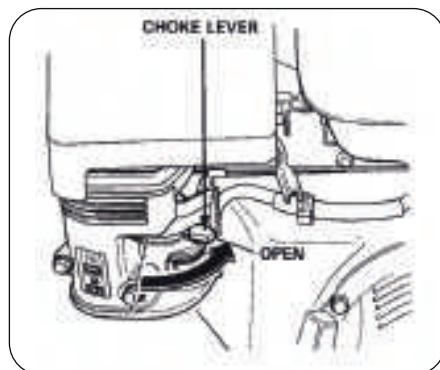

1. As the engine warms up, gradually move the choke lever to the OPEN position.

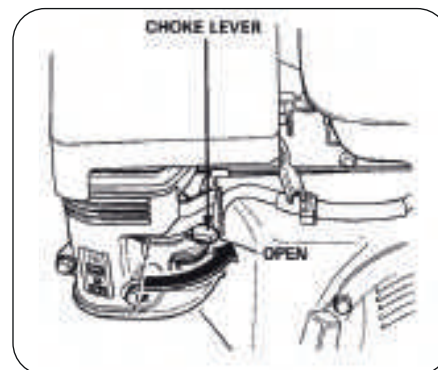

2. Position the throttle lever for the desired engine speed.

Oil Alert System

The Oil Alert system is designed to prevent engine damage caused by an insufficient amount of oil in the crankcase. Before the oil level in the crankcase can fall below a safe limit, the Oil Alert system will automatically shut down the engine (the engine switch will remain in the ON position).

If the Oil Alert system shuts down the engine, the Oil Alert lamp will flash when you operate the starter, and the engine will not run. If this occurs, add engine oil (p.8).

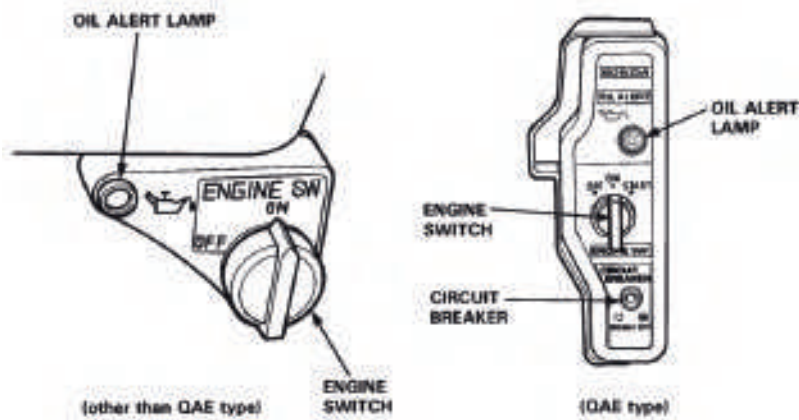

Circuit Breaker (QAE type)

The circuit breaker protects the battery charging circuit. A short circuit or a battery connected in reverse polarity will trip the circuit breaker.

The green indicator inside the circuit breaker will pop out to show that the circuit breaker has switched off. If this occurs, determine the cause of the problem, and correct it before resetting the circuit breaker.

Push the circuit breaker button to reset.

High altitude operation

At high altitude, the standard carburetor air-fuel mixture will be excessively rich. Performance will decrease, and fuel consumption will increase.

High altitude performance can be improved by installing a smaller diameter main fuel jet in the carburetor and readjusting the pilot screw. If you always operate the engine at altitudes higher than 6,000 feet above sea level, have these carburetor modifications performed by a dealership displaying the Honda Power Equipment Engines sign.

Even with suitable carburetor jetting, engine horsepower will decrease approximately 3.5% for each 1,000 foot increase in altitude. The effect of altitude on horsepower will be greater than this if no carburetor modification is made.

NOTICE

Operation of the engine at an altitude lower than the carburetor is jetted for may result in reduced performance, overheating, and serious engine damage caused by an excessively lean air/fuel mixture

STOPPING THE ENGINE

To stop the engine in an emergency, turn the engine switch to the OFF position. Under normal conditions, use the following procedure:

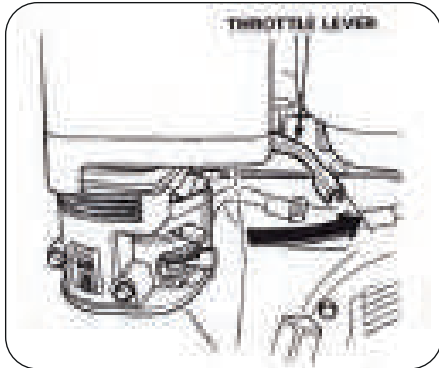

1. Move the throttle lever fully to the right.

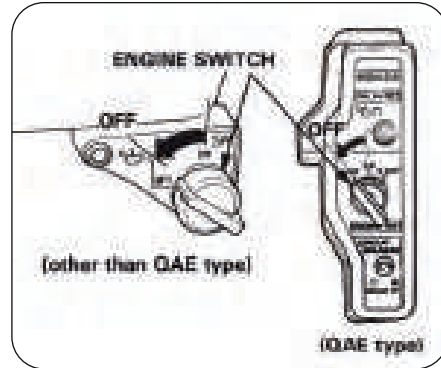

2. Turn the engine switch to the OFF position.

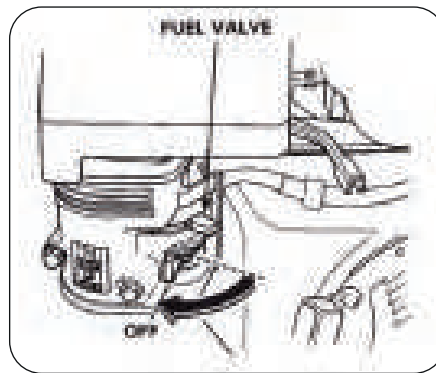

3. Turn the fuel valve to the OFF position

MAINTENANCE

Periodic maintenance and adjustment is necessary to keep the engine in good operating condition. Perform the service and inspection scheduled in the following table.



WARNINGS

Shut off the engine before performing any maintenance. If the engine must be run, make sure the area is well ventilated. The exhaust contains poisonous carbon monoxide gas; exposure can cause loss of consciousness and may lead to death.

NOTICE

Use only genuine HONDA parts or their equivalent. The use of replacement parts which are not of equivalent quality may damage the engine.

Maintenance Schedule

| ITEM <small>Performed at every indicated month or operating hour interval, whichever comes first.</small> | | Each Use | First month or 20 Hrs. | Every 3 months or 50 Hrs. | Every 6 months or 100 Hrs. | Every year or 300 Hrs. |
|---|------------------------------|-------------------|------------------------|---------------------------|----------------------------|------------------------|
| Engine Oil | Check Level Change | ● | | | | |
| Reduction gear oil (Applicable models only) | Check Level Change | | ● | | ● | |
| Air cleaner | Check Level Clean | ● | ○ Only the First Time | | | |
| Sediment Cup | Clean | | | | | |
| Spark Plug | Clean/ Readjust | ● | | | | |
| Spark Arrester (Optional part) | Clean | ● | | | | |
| Valve Clearance | Clean/ Readjust | | | | | ● |
| Fuel tank and strainer | Clean | | | | | ● |
| Fuel Line | Check (Replace if necessary) | Every 2 Years (2) | | | | |

NOTE

1. Service more frequently when used in dusty areas.
2. These items should be serviced by an authorized Honda dealer, unless the owner has the proper tools
3. and is mechanically proficient . See the Honda Shop Manual.

1. Oil change

Drain the oil while the engine is still warm to assure rapid and complete draining.

1. Remove the oil filler cap and drain plug to drain the oil.
2. Install the drain plug, and tighten it securely.
3. Refill with the recommended oil (see pages 8 and 9), and check the oil level.
4. Install the oil filler cap.

ENGINE OIL CAPACITY: 1.1 (1.2 US qt, 1.94 Imp qt)

REDUCTION GEAR OIL CAPACITY: 300 cc (10 US oz, 8.4 Imp oz)

ENGINE OIL

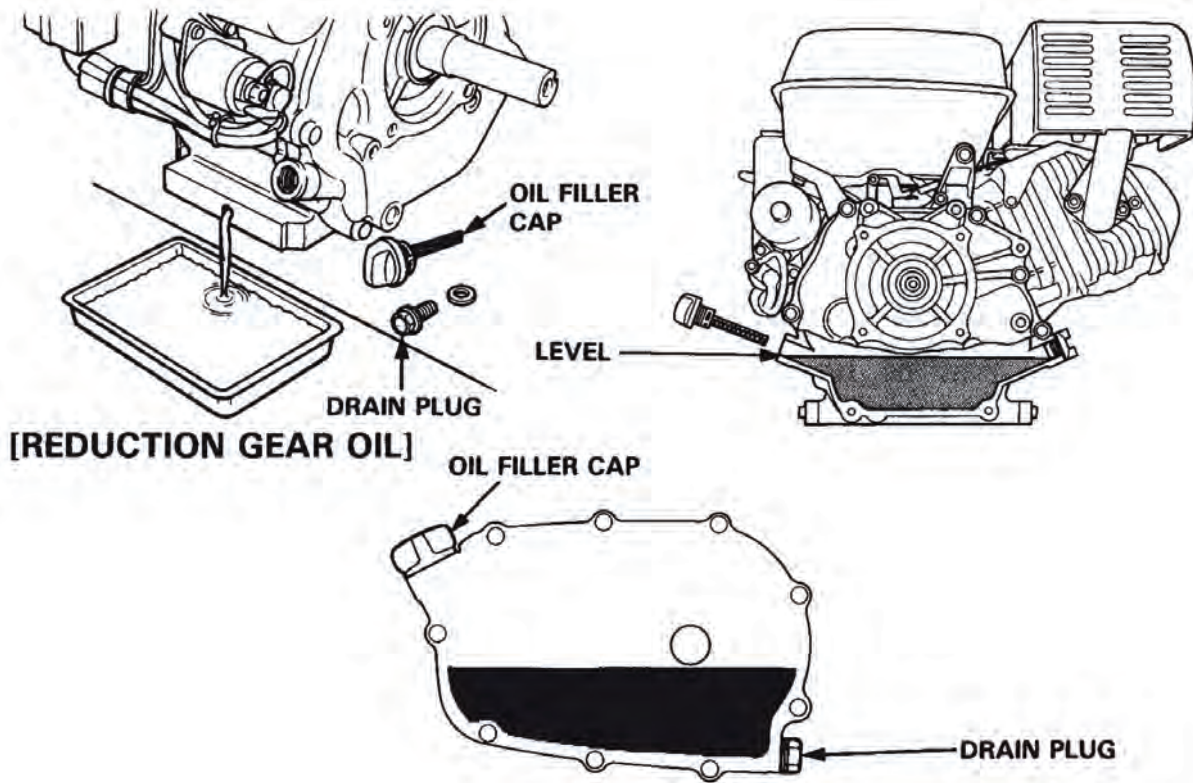
**WARNINGS**

Used motor oil may cause skin cancer if repeatedly left in contact with the skin for prolonged periods. Although this is unlikely unless you handle used oil on a daily basis, it is still advisable to thoroughly wash your hands with soap and water as soon as possible after handling used oil.

NOTE: Please dispose of used motor oil in a manner that is compatible with the environment. Do not throw it in the trash or pour it on the ground.

2. Air cleaner service

A dirty air cleaner will restrict air flow to the carburetor. To prevent carburetor malfunction, service the air cleaner regularly. Service more frequently when operating the engine in extremely dusty areas.

Never use gasoline or low flash point solvents for cleaning the air cleaner element. A fire or explosion could result.

NOTICE

Never run the engine without the air cleaner. Rapid engine wear will result from contaminants, such as dust and dirt, being drawn through the carburetor, into the engine.

1. Remove the wing nut and the air cleaner cover.
2. Remove the elements and separate them. Carefully check both elements for holes or tears and replace if damaged.
3. Foam element: Wash the element in a solution of household detergent and warm water, then rinse thoroughly, or wash in non flammable or high flash point solvent. Allow the element to dry thoroughly. Soak the element in clean engine oil, and squeeze out the excess oil. The engine will smoke during initial start-up if too much oil is left in the foam.
4. Paper element: Tap the element lightly several times on a hard surface to remove excess dirt, or blow compressed air through the filter from the inside out. Never try to brush the dirt off; brushing will force dirt into the fibers. Replace the paper element if it is excessively dirty.

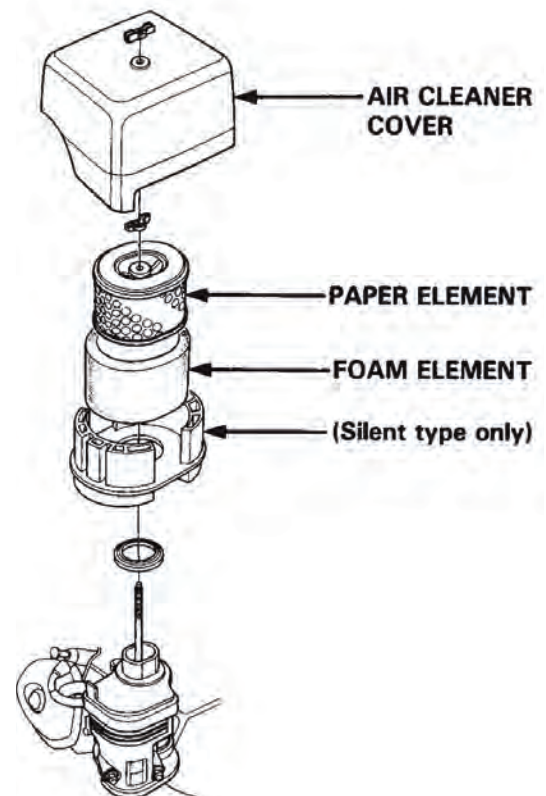

<Cyclone Type>

1. Remove the wing nut and the air cleaner cover. Remove the elements and separate them. Carefully check both elements for holes or tears and replace if damaged.
2. Foam element: Wash the element in a solution of household detergent and warm water, then rinse thoroughly, or wash in nonflammable or high flash point solvent. Allow the element to dry thoroughly. Soak the element in clean engine oil and squeeze out the excess oil. The engine will smoke during initial start-up if too much oil is left in the foam.
3. Paper element: Tap the element lightly several times on a hard surface to remove excess dirt, or blow compressed air through the filter from the inside out. Never try to brush the dirt off; brushing will force dirt into the fibers. Replace the paper element if it is excessively dirty.
4. Cyclone Housing: Remove the three special pan head screws, remove the housing, and wash the components with water. Dry the components thoroughly, and carefully reassemble them.

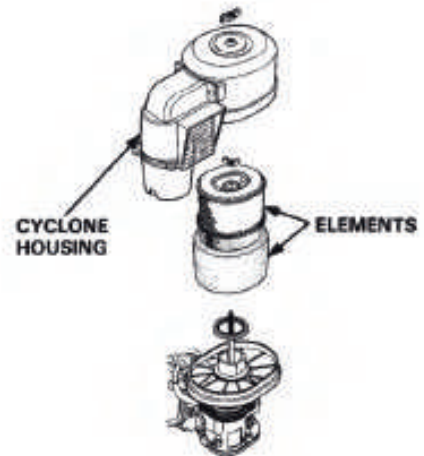
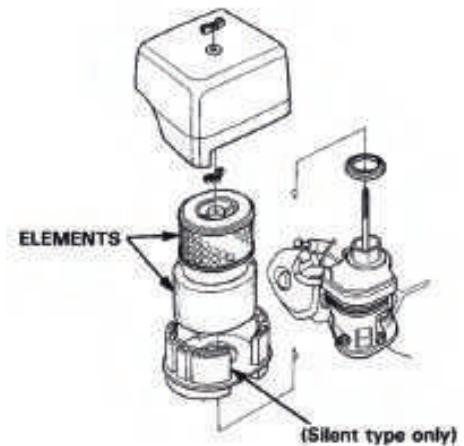

<Single element type>

1. Unscrew the wing nut, remove the air cleaner cover and remove the element.
2. Wash the element in a solution of household detergent and warm water, then rinse thoroughly, or wash in nonflammable or high flash point solvent. Allow the element to dry thoroughly.
3. Soak the element in clean engine oil and squeeze out the excess oil. The engine will smoke during initial start-up if too much oil is left in the element.
4. Reinstall the air cleaner element and the cover.

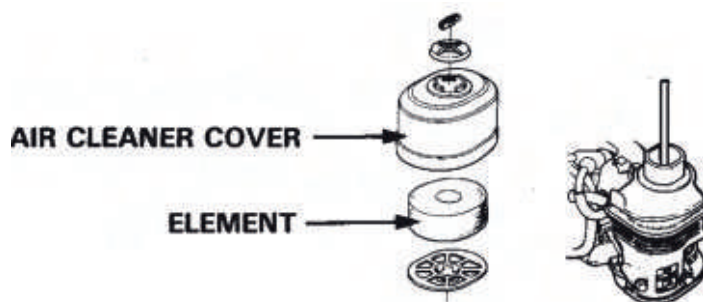

1. Unscrew the wing nut, remove the air cleaner cover and remove the element.
2. Wash the element in a solution of household detergent and warm water, then rinse thoroughly, or wash in nonflammable or high flash point solvent. Allow the element to dry thoroughly.
3. Soak the element in clean engine oil and squeeze out the excess oil. The engine will smoke during initial start-up if too much oil is left in the element.
4. Empty the oil from the air cleaner case and wash out any accumulated dirt with nonflammable or high flash point solvent. Dry the case.
5. Fill the air cleaner case to the level mark with the same oil that is recommended for the engine (see engine oil recommendations on page 8).
6. Reinstall the element and the cover.

OIL CAPACITY: GX240 • GX270 60 cc (2.0 US oz, 1.69 Imp oz)

GX340 • GX390 80 cc (2.7 US oz, 2.25 Imp oz)

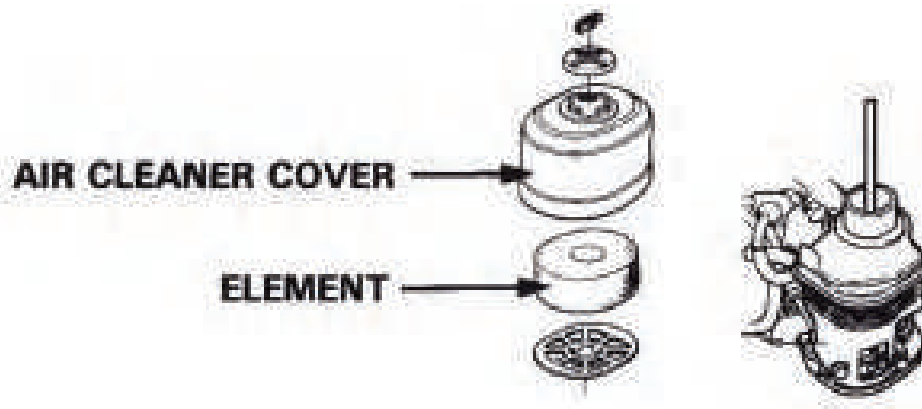

3. Sediment cup cleaning

- Gasoline is extremely flammable and is explosive under certain conditions. Do not smoke or allow flames or sparks in the area.
- After installing the sediment cup, check for leaks, and make sure the area is dry before starting the engine.

Turn the fuel valve to OFF. Remove the sediment cup and O-ring, and wash them in nonflammable or high flash point solvent. Dry them thoroughly, and reinstall securely. Turn the fuel valve ON, and check for leaks.

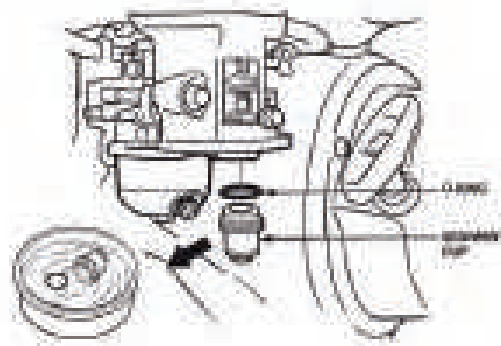

4. Spark plug service

Recommended spark plug: BPR6ES (NGK)
W20EPR-U (ND)

NOTICE

Use only the recommended spark plugs or equivalent. Spark plugs which have an improper heat range may cause engine damage.

To ensure proper engine operation, the spark plug must be properly gapped and free of deposits.

1. Remove the spark plug cap, and use a spark plug wrench to remove the plug.



WARNINGS

If the engine has been running, the muffler will be very hot. Be careful not to touch the muffler.

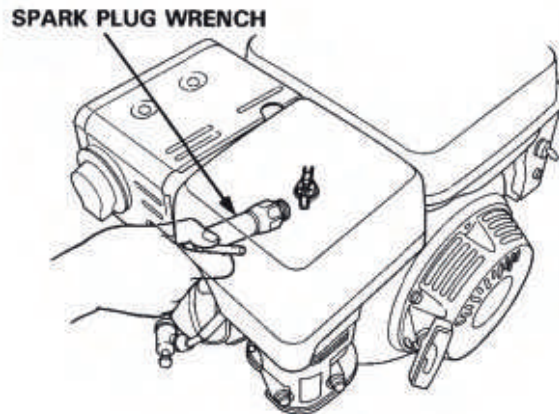

2. Visually inspect the spark plug. Discard it if the insulator is cracked or chipped. Clean the spark plug with a wire brush if it is to be reused.
3. Measure the plug gap with a feeler gauge. The gap should be 0.7-0.8mm (0.028-0.031 in)

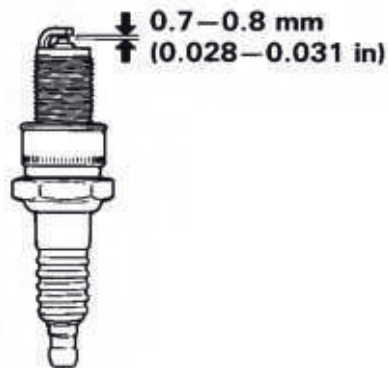

4. Check that the spark plug washer is in good condition, and thread the spark plug in by hand to prevent cross-threading

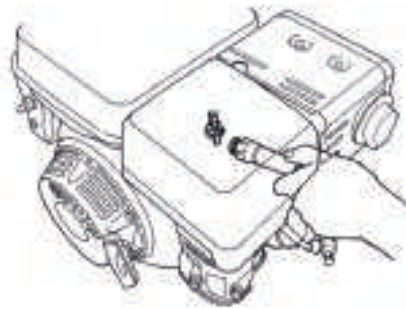

5. After the spark plug is seated, tighten with a spark plug wrench to compress the washer.

NOTE:

If installing a new spark plug, tighten 1/2 turn after the spark plug seats to compress the washer. If reinstalling a used spark plug, tighten 1/8-1/4 turn after the spark plug seats to compress the washer.

NOTICE

The spark plug must be securely tightened. An improperly tightened spark plug can become very hot and may damage the engine.

6. Spark arrester maintenance (optional part)

The spark plug must be securely tightened. An improperly tightened spark plug can become very hot and may damage the engine.



WARNINGS

The muffler becomes very hot during operation and remains hot for a while after stopping the engine. Be careful not to touch the muffler while it is hot. Allow it to cool before proceeding.

NOTICE

The spark arrester must be serviced every 100 hours to maintain its efficiency.

1. Remove the two 8 mm nuts (G) and remove the muffler from the cylinder.
2. Remove the three 4 mm screws (H) from the exhaust deflector (I), and remove the deflector.
3. Remove the four 5 mm screws (C) from the muffler protector (D), and remove the muffler protector.
4. Remove the 4 mm screw (E) from the spark arrester (J), and remove the spark arrester from the muffler (F).

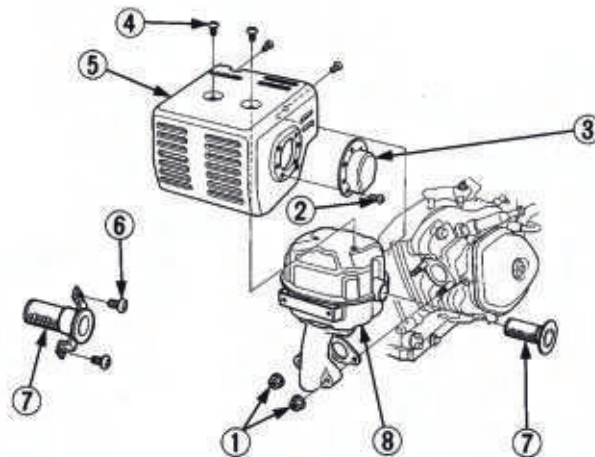

5. Use a brush to remove carbon deposits from the spark arrester screen.

NOTICE

Be careful not to damage the spark arrester screen.



NOTE:

The spark arrester must be free of breaks and holes. Replace, if necessary.

6. Install the spark arrester and the muffler in the reverse order of disassembly

6. Carburetor adjustment

1. Start the engine and allow it to warm up to normal operating temperature.
2. With the engine idling, turn the pilot screw in or out to the setting that produces the highest idle rpm. Usually the correct setting will be found to be:

| | GX240 | GX270 | | |
|---------------------|-------|-------|-------|-------|
| Dual element type | | | 2 1/2 | 2 1/4 |
| Single element type | 2 | 2 7/8 | | |
| Oil bath type | | | 2 1/4 | 2 1/4 |
| Cyclone Type | 2 | 2 | | |

NOTICE

Do not tighten the pilot screw against its seat; this will damage the pilot screw or seat.

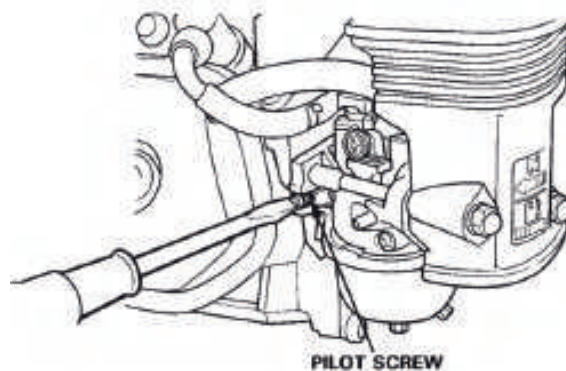

3. After the pilot screw is correctly adjusted, turn the throttle stop screw to obtain the standard idle speed.
Standard idle speed: 1400 ± 150 rpm.

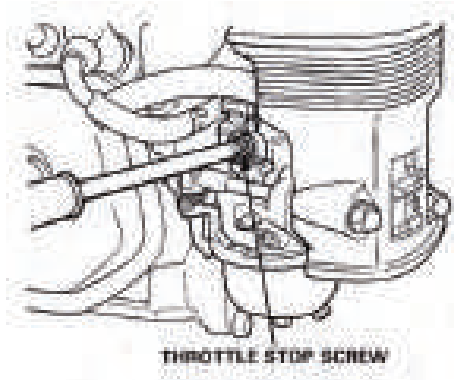

TRANSPORTING STORAGE



WARNINGS

- To avoid severe burns or fire hazards, let the engine cool before transporting it or storing it indoors.
 - When transporting the engine, turn the fuel valve to the OFF position and keep the engine level to prevent fuel spillage. Fuel vapor or spilled fuel may ignite.
- Before storing the unit for an extended period;

1. Be sure the storage area is free of excessive humidity and dust.
2. Drain the fuel...
 - a. With the fuel valve OFF, remove and empty the sediment cup.
 - b. Turn the fuel valve ON and drain the gasoline in the fuel tank into a suitable container.
 - c. Replace the sediment cup and tighten securely.
 - d. Drain the carburetor by loosening the drain screw. Drain the gasoline into a suitable container.



WARNINGS

Gasoline is extremely flammable and is explosive under certain conditions. Do not smoke or allow flames or sparks in the area.

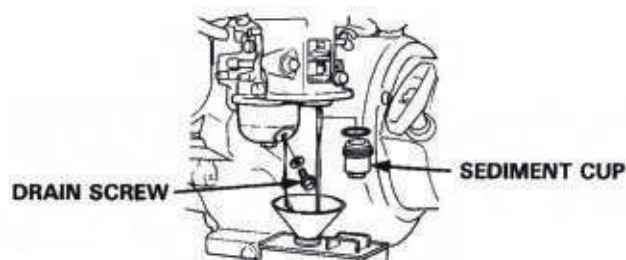

3. Change the engine oil.
4. Remove the spark plug and pour about a tablespoon of clean. engine oil into the cylinder. Crank the engine several revolutions to distribute the oil, then reinstall the spark plug.
5. Pull the starter rope slowly until resistance is felt. Continue pulling until the notch on the starter pulley aligns with the hole on the recoil starter (see illustration below). At this point, the intake and exhaust valves are closed, and this will help to protect the engine from internal corrosion

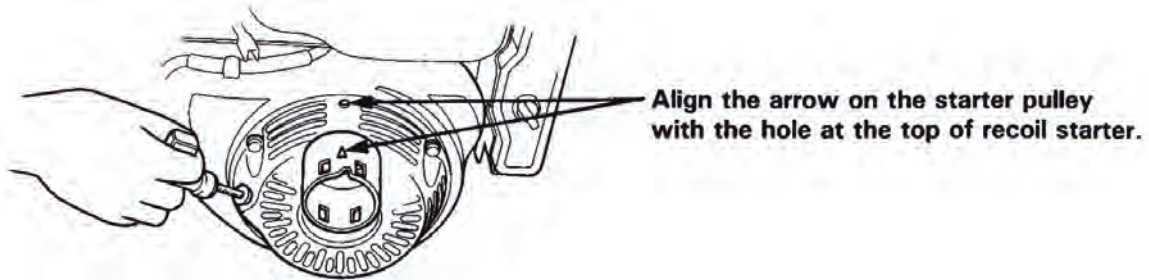

TROUBLESHOOTING

Engine will not start, using recoil starter:

1. Is the engine switch ON?
2. Does the oil alert lamp flash when the starter is operated?
3. Is the fuel valve ON?
4. Is there fuel in the fuel tank?
5. Is gasoline reaching the carburetor? To check, loosen the drain screw with the fuel valve on.



WARNINGS

If any fuel is spilled, make sure the area is dry before testing the spark plug or starting the engine. Fuel vapor or spilled fuel may ignite.

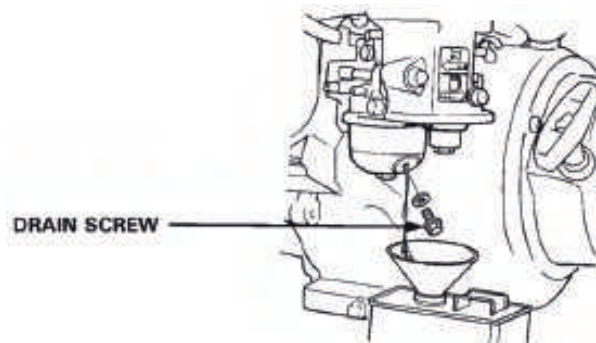

6. Is there a spark at the spark plug?
 - a. Remove the spark plug cap. Clean any dirt from around the spark plug base, then remove the spark plug.
 - b. Install the spark plug in the plug cap.
 - c. Turn the engine switch on.
 - d. Grounding the side electrode to any engine ground, and pull the recoil starter to see if sparks jump across the gap.
 - e. If there is no spark, replace the plug.

If OK, try to start the engine according to the instructions.

7. If the engine still does not start, take the engine to the dealer

Engine will not start, using electric starter:

1. Are the battery cables securely connected and free of corrosion?
2. Is the battery fully charged?

NOTE:

If the engine does not charge the battery, check the circuit breaker.

3. If the starter motor operates but the engine will not start, follow the troubleshooting procedures described under recoil starter operation.

SPECIFICATIONS

GX240 - GX270

| DIMENSIONS & WEIGHT | GX240 | GX270 |
|------------------------------|--|---|
| Description code | GC04 | GX270 |
| Cyclone Type | 2 | 2 |
| LENGTH x WIDTH x HEIGHT | 390 x 450 x 435 mm | |
| Dry Weight | 23.5 kg (51.8 lb) | |
| Engine Type | 4 - Stroke, overhead valve, single cylindrer | |
| Displacement (Bore x Stroke) | 242 cc (14 .8 cu in) 173 x 58 mm (2 .9 x 2.3 in)] | 270 cc (16.5 cu in) [77 x 58 mm (3.0 in x 2.3 in)] |
| Max. Output | 8.0 HP / 3.600 rpm | 9.0 HP / 3.600 rpm |
| Max. Torque | 1.7 kg-m (12.29 ft-lb)/2,500 rpm | 1.95 kg (14. 1 ft-lb)/2,500 rpm |
| Fuel Consumption | 230 g/HPh (0. 7 lb/HPh) | |
| Cooling System | Forced Air | |
| Ignition System | Transistorized Magneto | |

GX340 - GX390

| DIMENSIONS & WEIGHT | GX340 | GX390 |
|------------------------------|---|---------------------------------|
| Description code | GC05 | GCAA |
| Cyclone Type | 2 | 2 |
| LENGTH x WIDTH x HEIGHT | 390 x 450 x 435 mm (15.4 X 17.7 X 17.1 in) | |
| Dry Weight | 31 kg (68.4 lb) | |
| Engine Type | 4 - Stroke, overhead valve, single cylindrer | |
| Displacement (Bore x Stroke) | 377 cc (20.6 cu in) 82 x 64 mm (2.9 x 2.3 in)] | 270 cc (16.5 cu in) 2.3 in)] |
| Max. Output | 11.0 HP / 3.600 rpm | 13 HP / 3.600 rpm |
| Max. Torque | 2.4 kg-m (17.36 ft-lb)/2,500 rpm | 2.7 kg (19.5 ft-lb)/2,500 rpm |
| Fuel Consumption | 230 g/HPh (0.7 lb/HPh) | |
| Cooling System | Forced Air | |
| Ignition System | Transistorized Magneto | |
| PTO Shaft Rotation | Counterclockwise | |

NOTE: Specifications may vary according to the types, and are subject to change without notice

QAE TYPE

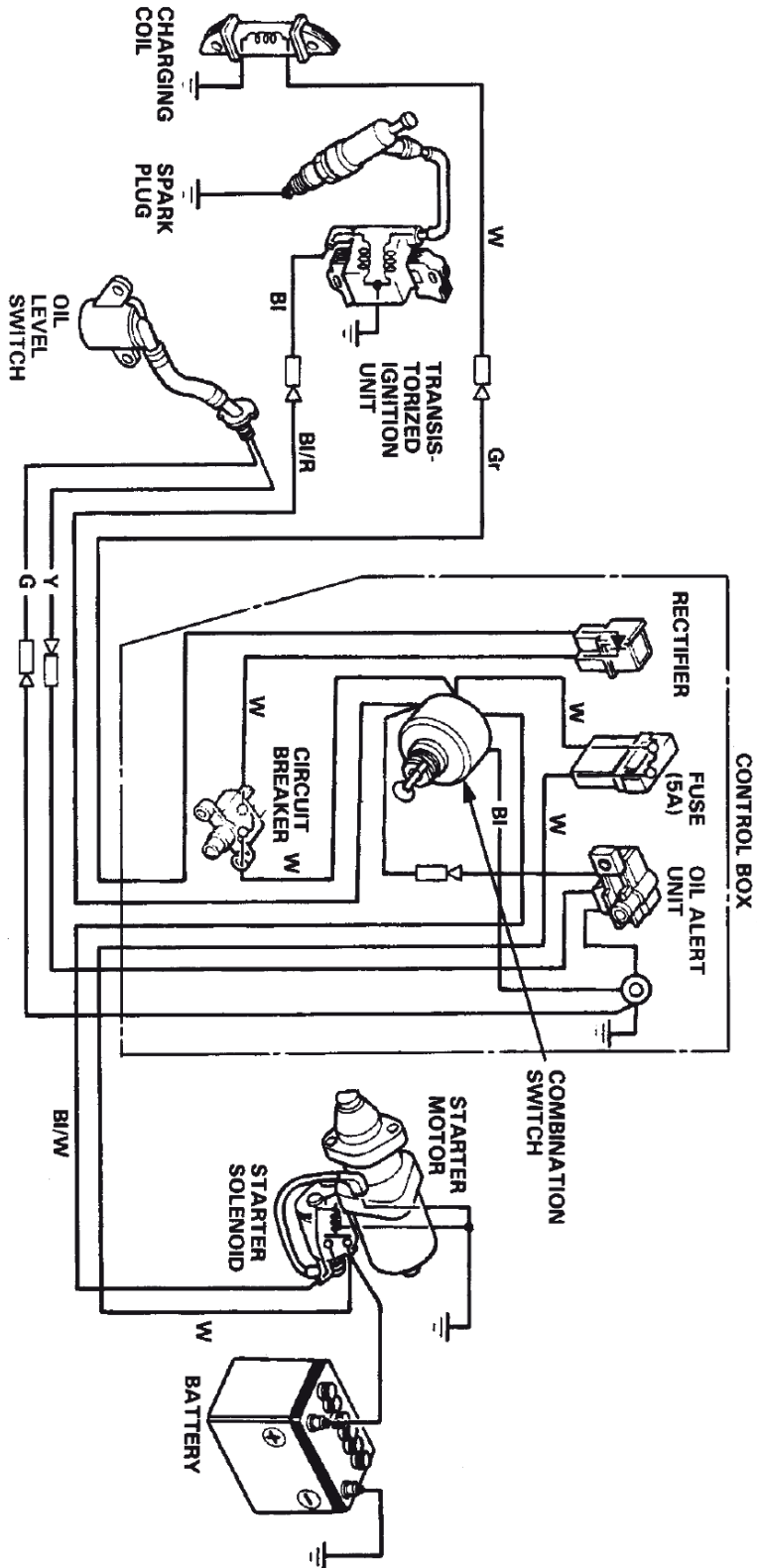

| | | | |
|----|--------|----|-------|
| BI | BLACK | Gr | GRAY |
| Y | YELLOW | R | RED |
| W | WHITE | G | GREEN |

COMBINATION SW

| | | | | |
|-------|-----------------------|-----------------------|-----------------------|-----------------------|
| | IG | E | ST | BAT |
| OFF | <input type="radio"/> | <input type="radio"/> | | |
| ON | | | | |
| START | | | <input type="radio"/> | <input type="radio"/> |

Except QAE Type

NOTE: Wiring diagrams may vary according to the types.

| | |
|----|--------|
| BI | BLACK |
| Y | YELLOW |
| G | GREEN |

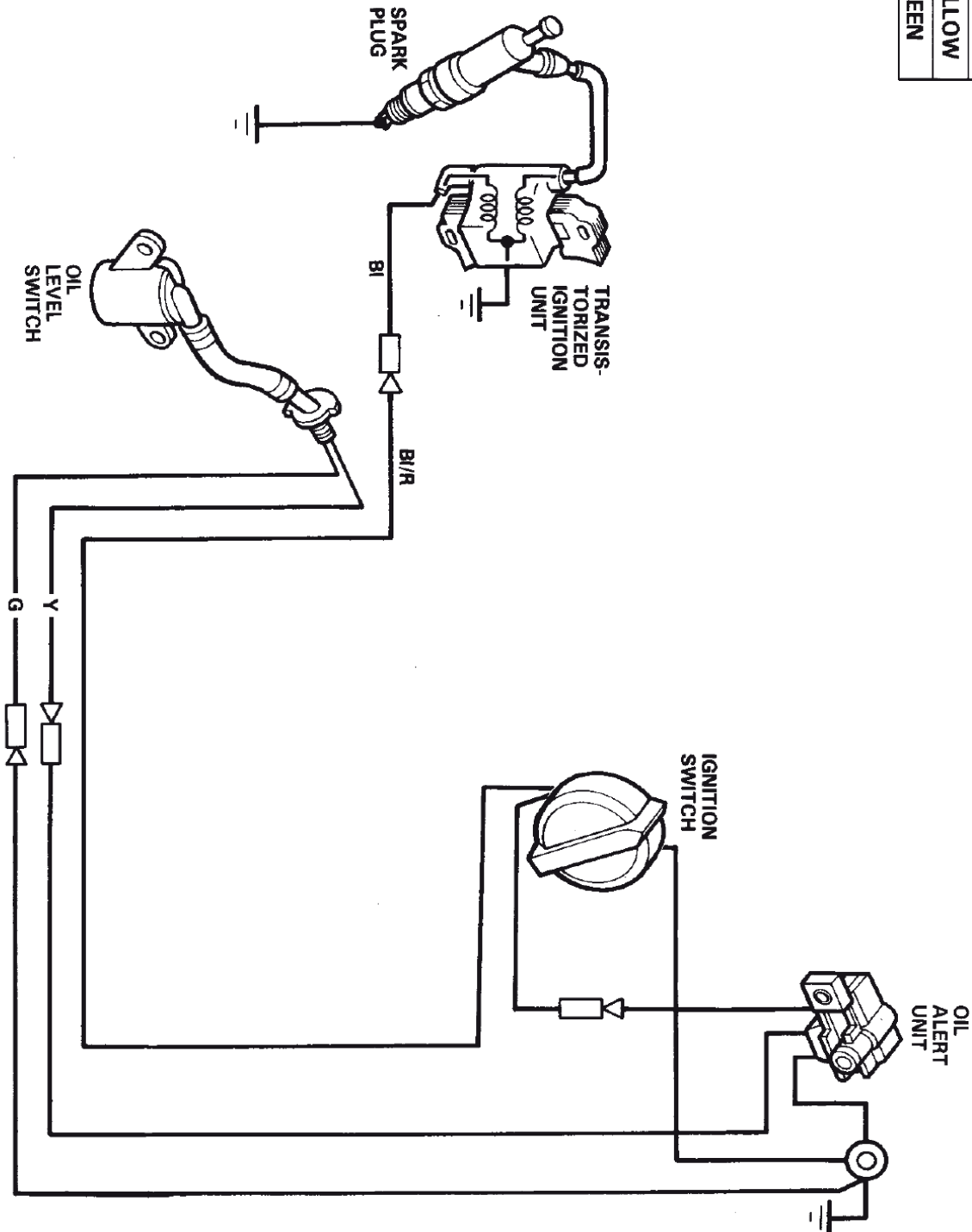

3.SAFE USE

This mark denotes those items that are very important for safety. Please be sure to obey them.

1. Do not allow people who do not understand this owner's manual to operate the engine.
2. Do not run engine indoors or where the ventilation is poor. (The exhaust gas contains carbon monoxide, an odorless and harmful substance.)
3. Do not place hands or feet near moving or rotating parts. (Be sure to cover the area around the power take off shaft and belts that link the engine with other equipment.)
4. Do not store, spill, or use gasoline near heat or flame or equipment that uses flame or sparks, such as stoves, ovens, water heaters, etc. (An explosion could occur.)
5. Do not add fuel indoors or where the ventilation is poor.
6. Do not smoke when adding fuel.
7. Do not remove the fuel tank cap or add fuel while the engine is running or hot. (Add fuel after the engine has cooled by waiting 2 or more minutes after the engine is stopped.)
8. Do not operate the engine when gasoline has been spilt, when there is the smell of gasoline, or when there is a danger of explosion.
9. Do not transport the engine with fuel in tank. (If fuel were to spill it could cause a fire.)
10. Do not stop the engine by using the choke lever.
11. Do not unreasonably adjust the engine speed.
12. Do not check for spark with the spark plug removed.
13. Do not operate the engine with the muffler or air cleaner removed. (Especially for the muffler, check the tightness of mounting screw, damage and leakage periodically, and if abnormality is found, repair or replace it.)
14. Do not operate the engine with grass, leaves, or other combustible material in muffler area.
15. Do not touch the high-voltage cord or spark plug cap.
16. Occasionally inspect the fuel system components to check for cracks and leaks. Replace components when necessary.
17. Remove trash, grass, and other debris from around the cooling fins and recoil starter. (When doing this be sure to stop the engine and attached equipment and wait until the engine has cooled.)
18. To prevent burns, do not touch the muffler or other engine parts that have become hot.
19. Always use new gasoline. (Using old gasoline could cause build up in the carburetor, which could cause poor engine operation.)
20. Use genuine Mitsubishi Meiki engine parts. Not using genuine parts could result in engine damage and premature wear.



WARNING

The important safety instruction items shown in this operation manual do not cover all possible statuses or conditions. Although we pay sufficient attention for safety, the person who uses or maintains the engine is requested to pay sufficient attention for safety as well.



3.2 Emission Label

Emission label "COMPONENT NAMES"

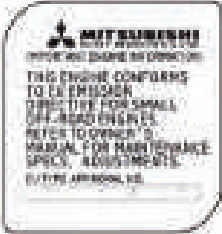
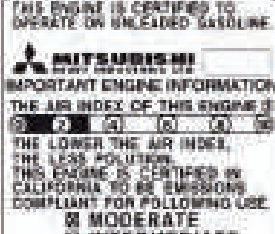
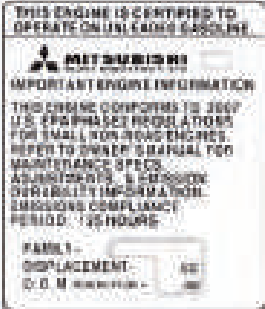
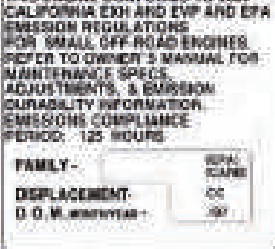
| | | | |
|--|--|--|--|
|  | <p>The emission label applicable to engines which are used in the EU.</p> |  | <p>The emission label applicable to engines which are used in California, and in the United States (and in Canada), page 30 "Emission System Warranty" is applied.</p> |
|  | <p>The emission label applicable to engines which are used in the United States (and in Canada except the state of California), page 28 "Emission System Warranty" is applied.</p> |  | |

3.3 Component Names

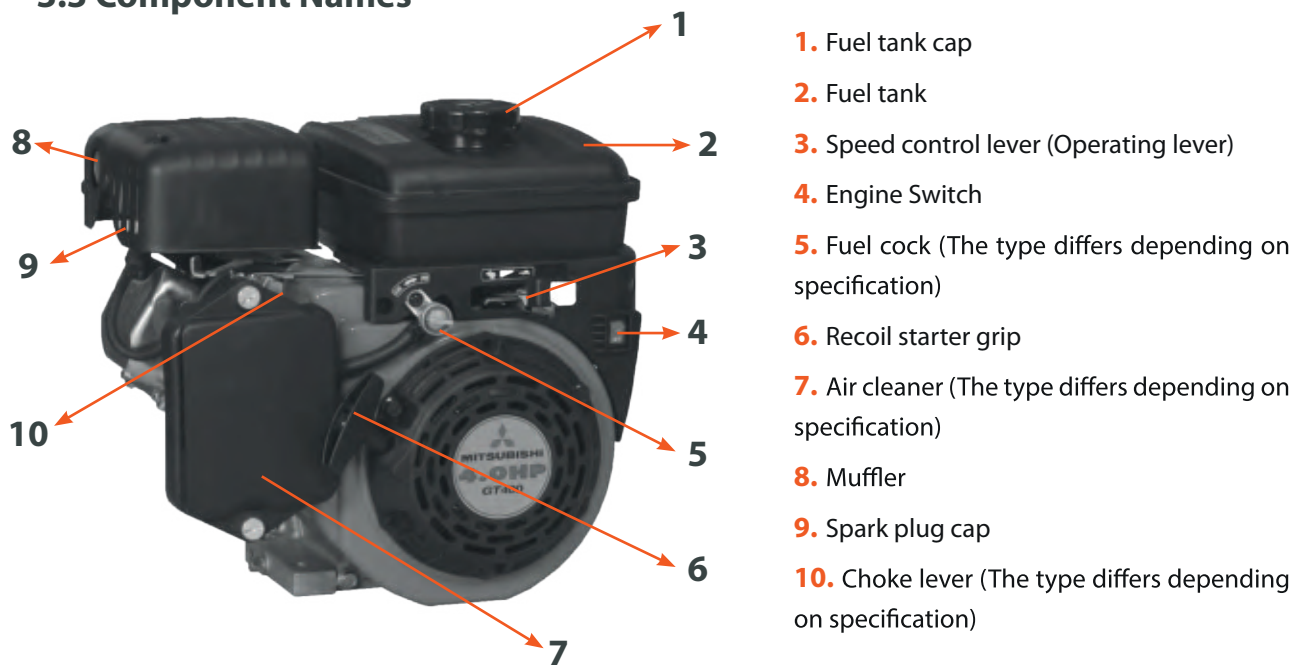



- 11. Oil gauge & oil filler cap
- 12. Oil drain plug
- 13. Power take off shaft
- 14. Emission label

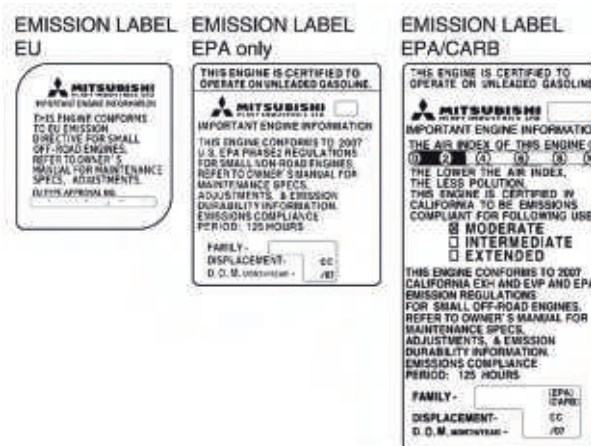

3.4 Fuel and Engine Oil

Fuel

- Use clean, fresh, unleaded gasoline. (Do not use leaded gasoline.)
- Use gasoline within 30 days of purchase. Do not use old gasoline. Doing so could cause problems.
- Do not mix oil into the gasoline.
- Do not overflow the gasoline when filling the fuel tank. (Leave several centimeters of space at the top of the tank.)



WARNING

Flame and heat can cause gasoline to explode. Be sufficiently careful of flame and heat when handling gasoline

Engine Oil

Engine is shipped from Mitsubishi Heavy Industry Ltd. without oil. Before starting the engine, be sure to conduct an oil inspection by following the instructions given below.

1. Place the engine on a level surface when adding oil and conducting inspections.
2. Check the oil level without the oil gauge screwed in.
3. Fill the oil up to the F-level of the oil gauge (correct level).
4. Before starting the engine, tightly screw in the oil gauge.
5. Replace or add engine oil following the table below.
6. For oil, use high-quality pure API class oils with a grade of SE or higher.

3.5 PRE OPERATION ENGINE INSPECTION

Be sure to check the following before operating the engine.

 **1. Fuel inspection**

- Is there gasoline in the tank?
- Is old gasoline being used?
- Add the correct fuel following the instructions "FUEL AND ENGINE OIL".
- Is the fuel tank cap closed correctly?

 Be sufficiently careful of heat and Be flame sufficiently when handling-careful and adding fuel. Not doing so could cause a fire or explosion.

 **2. Air Cleaner Inspection**

- Is the air cleaner element dirty or is the air cleaner oil (oil bath type) insufficient?
- When the air cleaner element is dirty or oil in the air cleaner is dirty or insufficient, check and maintain according "CARE OF THE ENGINE" "INSPECTION AND MAINTENANCE".

 **3. Engine Oil Inspection**

- Is the engine filled with the specified amount of engine oil? And is the oil dirty?
- If there is not enough oil, if it is dirty, or it has been used longer than the specified time, follow the inspection and maintenance instructions "FUEL AND ENGINE OIL" and check "CARE OF THE ENGINE".

 **4. Inspect the tightness of all fastener screws**

- Are all the screws tight?
- Be sure to check the screws used to fasten the muffler. (Do this when the muffler is cold.)

 **5. Component Cleaning Inspection**

- Are there grass, leaves, or combustible materials around the muffler?
- Are there grass, leaves, or combustible materials around the recoil starter air intake?
- If there to is trash, etc., in the vicinity, be sure to remove it before operating the engine.

 **6. Fuel and oil leaks inspection**

Are there any fuel or oil leaks? If any are found have the engine repaired.

Standard fuel tank capacity and oil quantity for the various models

| Model | Fuel Tank Capacity | Engine Oil Quantity |
|-------|--------------------|---------------------|
| GT240 | 1.5 e | 0.4 e |
| GT400 | 2.5 E | 0.6 e |
| GT600 | 3.8 e | 0.6 e |
| GT241 | 1.5 e | 0.4 e |

3.6 STARTING AND STOPPING ENGINE

Before starting the engine, carefully read and understand the "SAFE USE" and "PRE-OPERATION ENGINE INSPECTION" sections of this instruction manual.

Fuel Cock

Cock type without strainer

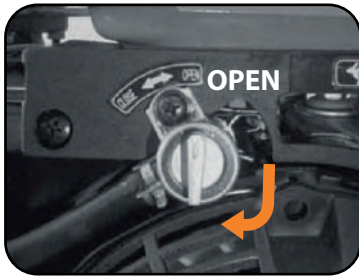

Cock type with strainer cup



Open fuel cock

Engine switch (Rocker Type)



Push the engine switch to the ON (I) position.

After Starting

- After starting the engine, gradually return the choke lever to the open position while watching how the engine is running.
- After warm-up operation (about 5 minutes), align the throttle with the required speed.



STOP

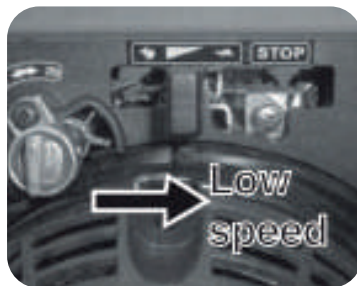

Move the speed control to the slow position and keep the engine running for 1 or 2 minutes.



Push the engine switch to the OFF (0) position or turn the key switch to the OFF (0) position.

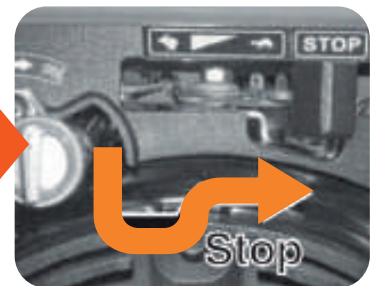

Move the lever further to the right direction from the slow position to stop.

Speed control lever & Engine Switch

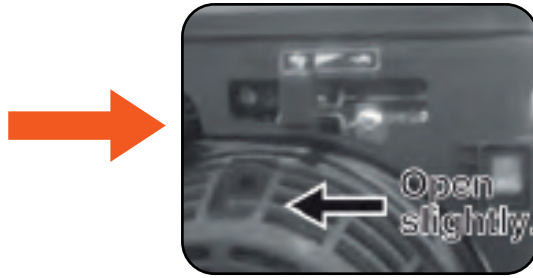

Open the speed control lever a little toward the high-speed side.

Choke lever

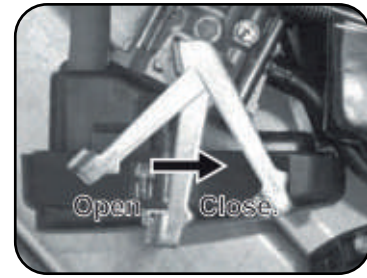

- Close the choke fully during cold weather or when the engine is hard to start.
- Open the choke partially or fully during hot weather or when the engine has warmed up.

Starting with the electric-starter (GT600)

- Starting with the electric-starter (optional specification/GT600)
- Turn the key switch to the START(e) position.
- If the engine does not start after running of the electric starter for 5 seconds, wait 5 seconds before trying to start again.
- After turning the switch to the START(6) position and releasing the key switch will automatically return to the ON (I) position.



Recoil start

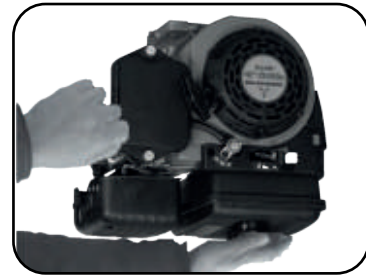

- Hold onto the starter grip and lightly pull it until the compression position is reached and then pull swiftly from this position.
- Slowly return the starter grip to its original position after the engine starts.

Fuel cock

Cock type without strainer



Close the fuel cock.

Cock type with strainer cup

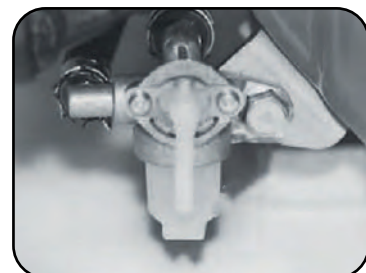

Care Of The Engine



Daily and regular care of the engine is important to assure safe, proper, and long-term operation of the engine. Refer to the regular inspection table when conducting inspections and maintenance.

Regular inspection table

| ITEM | Before Every Operation | Every 25 hours | Every 50 hours | Every 100 hours |
|--|-----------------------------|-----------------------|----------------|-----------------|
| Inspection and tightening of bolt and nut at each place | ● | | | |
| Engine oil level check and supply | ● | | | |
| Change of engine oil | | ○ Only the First Time | ● | |
| Check for fuel and oil leaks. | | | | |
| Check and cleaning of air cleaner | ● | | | |
| Cleaning around the recoil starter | ● | | | |
| Cleaning of circumference of the muffler cover | ● | | | |
| Check and cleaning of spark plug | ● | | | |
| Check and cleaning of spark plug | | | ● | |
| Check and cleaning of fuel cock (cock with strainer cup specification) | | | ● | |
| Removal of carbon in combustion chamber | | | | ● |
| Check and adjustment of valve clearance | | | | ● |
| Replace the fuel lines. | 3 years (or when necessary) | | | |

Items marked with a ● require advanced skill and tools, so they should be done by the distributor.



INSPECTION PRECAUTION ITEMS

Conduct inspections on a level and well-lit area.

- Detach the spark plug wires during inspections and maintenance to prevent the engine from starting unintentionally.
- Immediately after operation, the engine is hot, so do not touch it.
- When handling fuel (gasoline), never use heat or flame.
- When fuel or oil has been spilled, clean it promptly.
- Do not wash the engine with water.
- Do not unreasonably change the engine speed (Have it done by the distributor.)
- The inspection times listed in the regular inspection table are recommended for general use conditions. The equipment used or the work area could cause engine operation to degrade from debris or dust. In such a case, stop working and clean the engine in a safe area.

general use conditions. The equipment used or the work area could cause engine operation to degrade from debris or dust. In such a case, stop work and clean the engine in a safe area.

INSPECTION AND MAINTENANCE

Before each operation

Adding engine oil

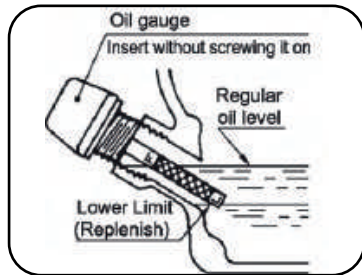

Be sure to check the amount of oil before each operation and fill the reservoir to the proper level. Change the oil if it is dirty.

Cleaning and inspecting components

- Clean the area around the muffler cover. (Remove trash, etc.)
- Inspect and tighten all nuts and bolts. (Are the muffler nuts loose?)
- Clean around the recoil starter. (Remove trash, etc.)
- Inspect fuel spills and oil leaks. (Completely wipe away fuel spills.)

Air cleaner inspection and maintenance

Semi-dry type

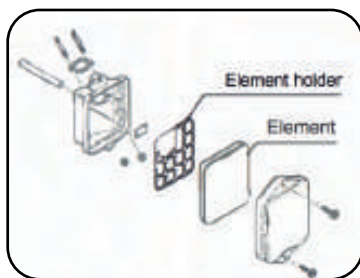

When the element is dirty or the oil has run out, dry the element, soak it in kerosene, and vigorously wring out the element with one hand.

Oil bath type (optional specification)

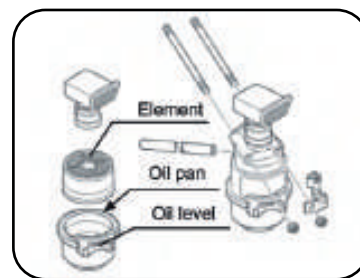

When the oil level is low, add oil to raise it to the correct level. When the element is very dirty, wash the oil pan and the element with kerosene, soak the element in engine oil, and shake or wring it until dripping stops.



Use of heat or flame is absolutely prohibited.

First 25 hours and each 50 hours of operation

Change the engine oil

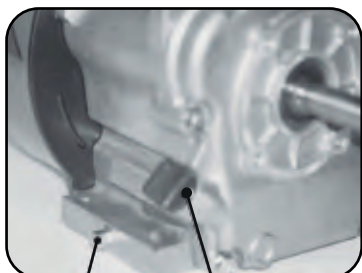

Drain Plug / Oil Gauge

(Only the first 25 hours)
While the engine is still warm, drain the oil from the drain plug and replace it with new oil.

Clean maintain the spark plug



Remove the carbon attached to the electrode, polish the electrode with emery paper, and adjust the electrode gap.

Burns could be caused by hot oil touching the skin, so be sufficiently careful.

Inspection and cleaning of the fuel cock (Cock with strainer cup specification only)

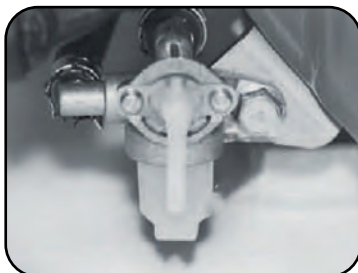

Remove the strainer cup of fuel cock , remove the deposit in the cup and clean the net.

Spark plug product Nos.

| | | | | |
|-------------------|--------|--------|----------|-------|
| Manufacturer name | NGK | Denso | Champion | NHSP* |
| Product No. | BP6HS | W20FP | L66Y | E6TC |
| Product No. | BPR6HS | W20FPR | RL82YC | E6RTC |

* Nanjing Huade Spark Plug Co., Ltd.

Long Term Storage

1. If the engine is not used for more than 30 days, changes in the fuel quality could cause poor engine starting, etc., so to prevent this loosen the fuel drain screw to drain out the fuel from the carburetor. Also open the fuel cock to drain the fuel from the fuel tank.



When doing this, be sufficiently careful in how the fuel is handled.
Handling around heat or flame is absolutely prohibited.

2. When storing the engine, remove the spark plug, pour 2 to 3 cc of engine oil into the cylinder, turn the crank shaft several times, replace the spark plug, and stop at the crank shaft at the point of compression.
3. Wipe the outside of the engine with a cloth soaked in oil. Do not wash the engine with water.
4. Store in a location with low humidity.

Trouble Shooting

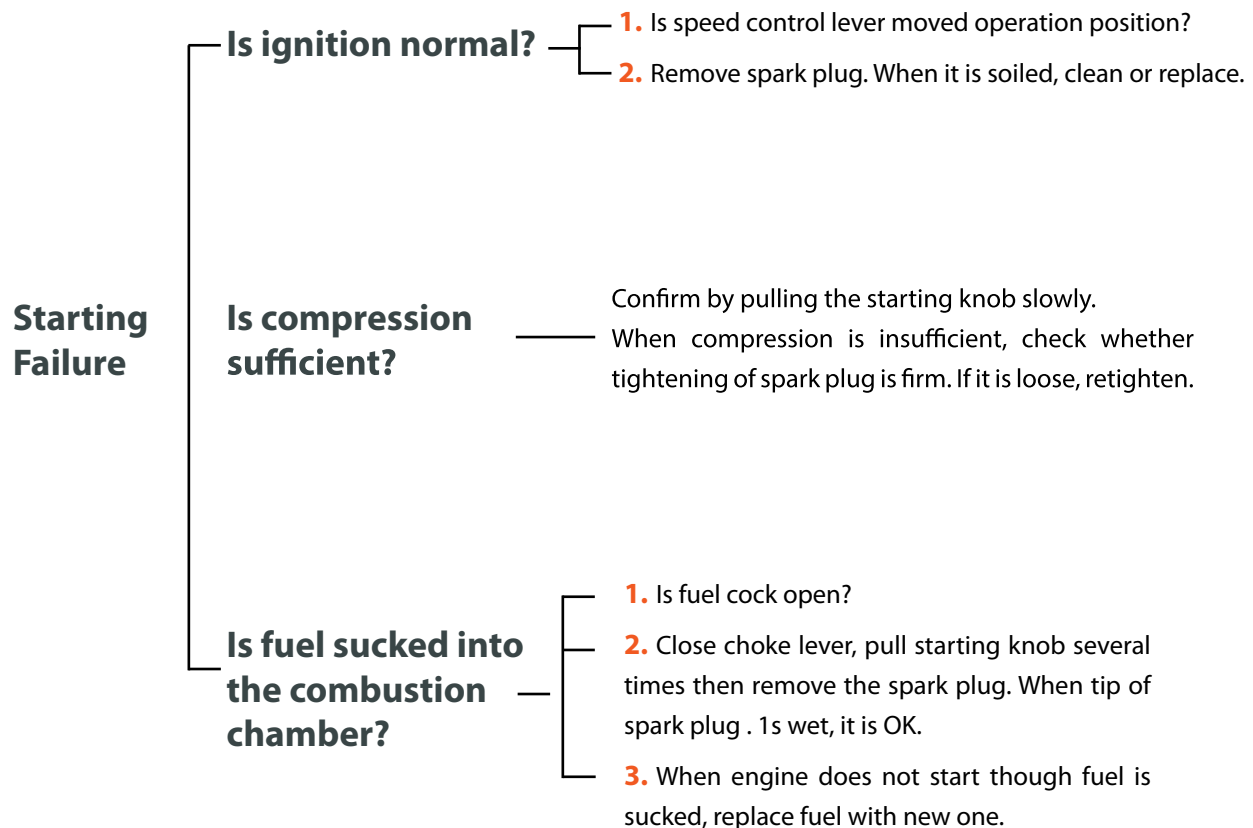

When the engine does not start in spite of above mentioned inspection, ask the distributor or repair factory for inspection.

PWCD5T

TECHNICAL PARAMETERS

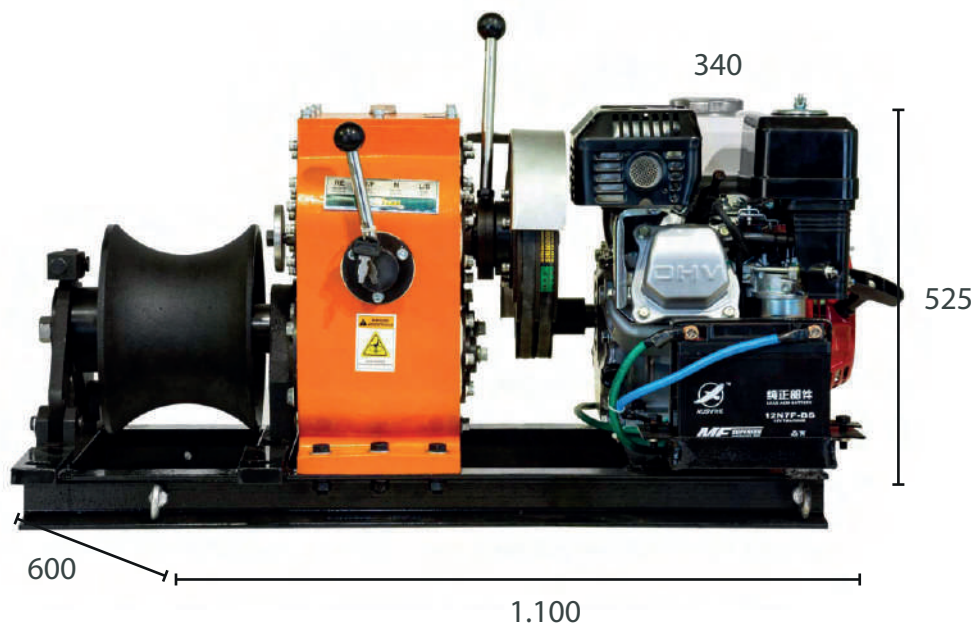

| PARAMETERS | GEAR | | | |
|------------|------|------|------|------|
| | I | | II | |
| | FAST | SLOW | FAST | SLOW |
| CAPACITY | 2,5 | 5 | 0,9 | 1,5 |
| SPEED | 8 | 4 | 24 | 13 |

| CODE | PWCD5T |
|--------------|---------------------|
| CAPACITY | 11.023 Lb |
| SPEED | 13 - 79 Ft / Min |
| MOTOR | Electrical Starting |
| TOTAL WEIGHT | 326 Lb |
| TRANSMISSION | Mechanics |

WARRANTY

1 Year Included
 2 Year Extended
 10Years Parts Service Availability

WINCHE PWCD5TTM

TECHNICAL PARAMETERS

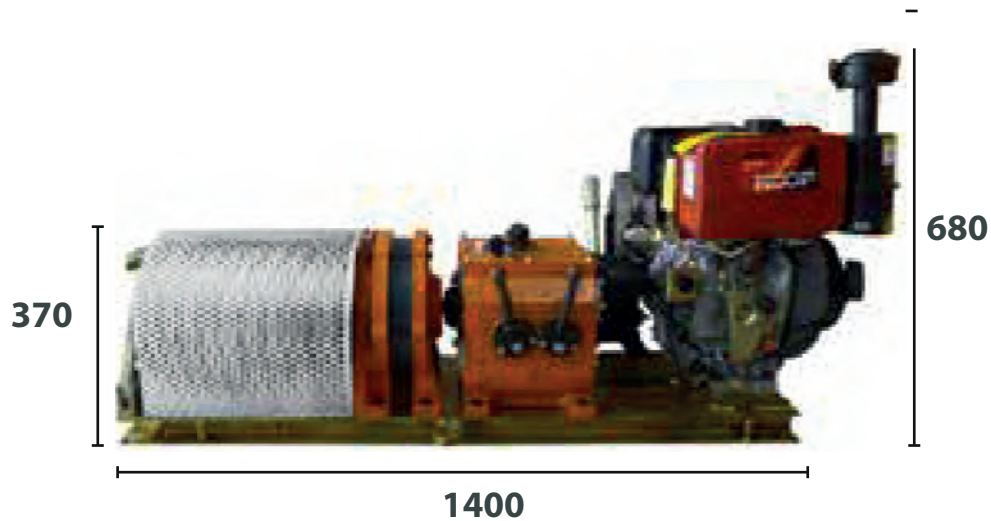

Dimensions in mm

| PARAMETERS | GEAR | | | |
|------------|------|------|------|------|
| | I | | II | |
| | FAST | SLOW | FAST | SLOW |
| CAPACITY | 2,5 | 5 | 0,9 | 1,5 |
| SPEED | 8 | 4 | 24 | 13 |

| CODE | PWCG3T |
|--------------|------------------|
| APPLICATION | Pulling |
| CAPACITY | 11.000 Lb |
| SPEED | 18 - 29 Ft / Min |
| MOTOR | Diesel 18 f - 9p |
| OIL FLOW | 19 L / min |
| PRESSURE | 1.400 psi |
| IWRC ROPE | 3/8" x 98 ft |
| TOTAL WEIGHT | Pulling |

WARRANTY 3 GEAR INCLUDED

TECHNICAL SPECIFICATIONS

Winche PWCG1T

Technical Parameters

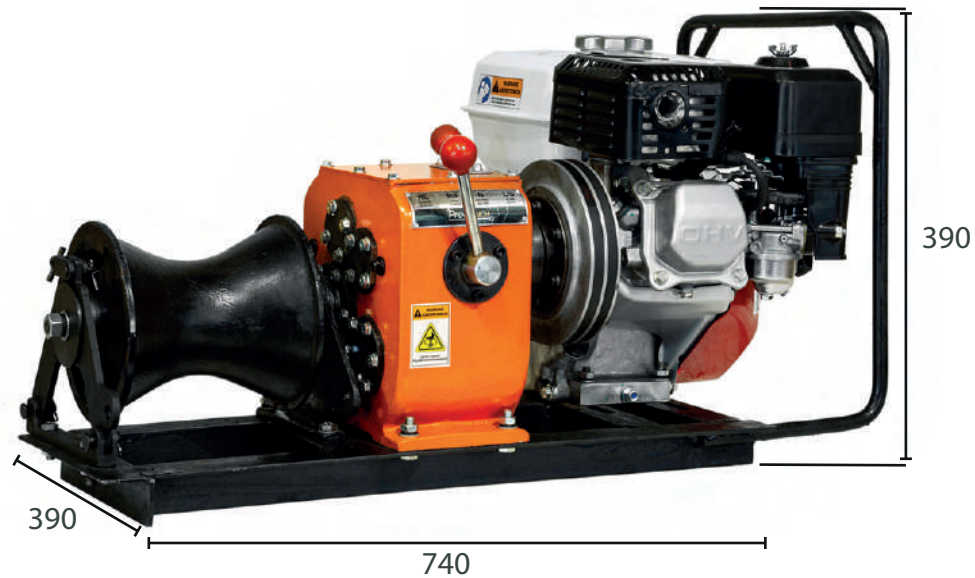

| PARAMETERS | GEAR | | |
|------------|---------|------|------|
| | REVERSE | FAST | SLOW |
| CAPACITY | N/A | 0.6 | 0.8 |
| SPEED | 12 | 15 | 10 |

| CODE | PWCG1T |
|--------------|-------------------------|
| CAPACITY | 1.763 Lb |
| SPEED | 33 - 49 Ft / Min |
| MOTOR | 4Hp Mitsubishi Gasoline |
| TOTAL WEIGHT | 84 Lb |
| TRANSMISSION | Manual |

WINCHE PWCG3T

TECHNICAL PARAMETERS

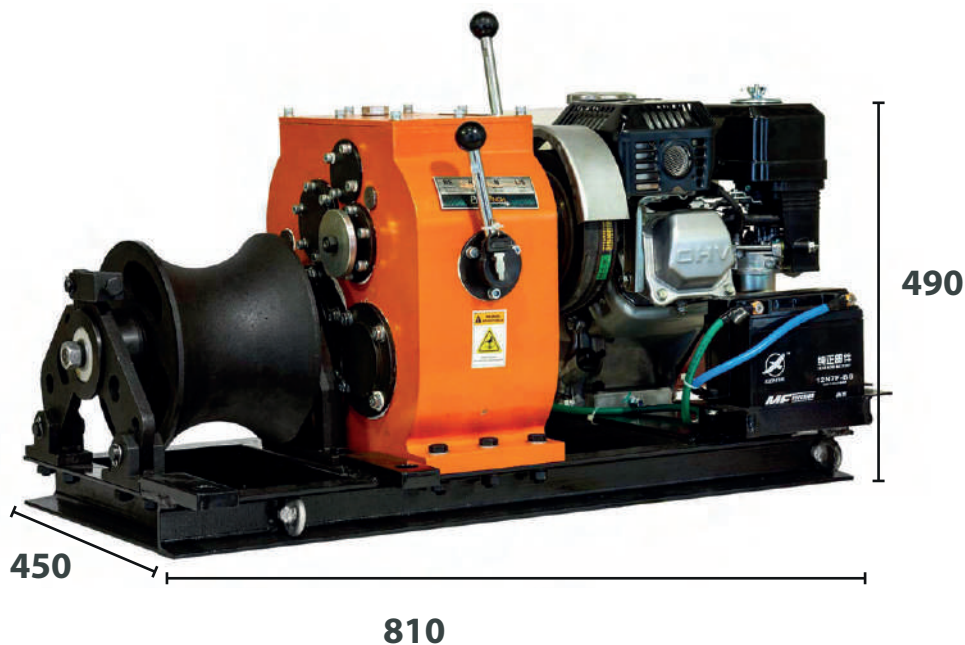

| PARAMETERS | GEAR | | |
|------------|---------|------|------|
| | REVERSE | FAST | SLOW |
| CAPACITY | N/A | 1.8 | 3 |
| SPEED | 4 | 9 | 5 |

| CODE | PWCG3T |
|--------------|----------------------|
| CAPACITY | 6.613 Lb |
| SPEED | 13 - 30 Ft / Min |
| MOTOR | Honda GX200 - 6.5 HP |
| TOTAL WEIGHT | 181 Lb |
| TRANSMISSION | Manual |
| APPLICATION | Pulling & Lifting |

WARRANTY 3 GEAR INCLUDED

WINCHE PWCG5T

TECHNICAL PARAMETERS

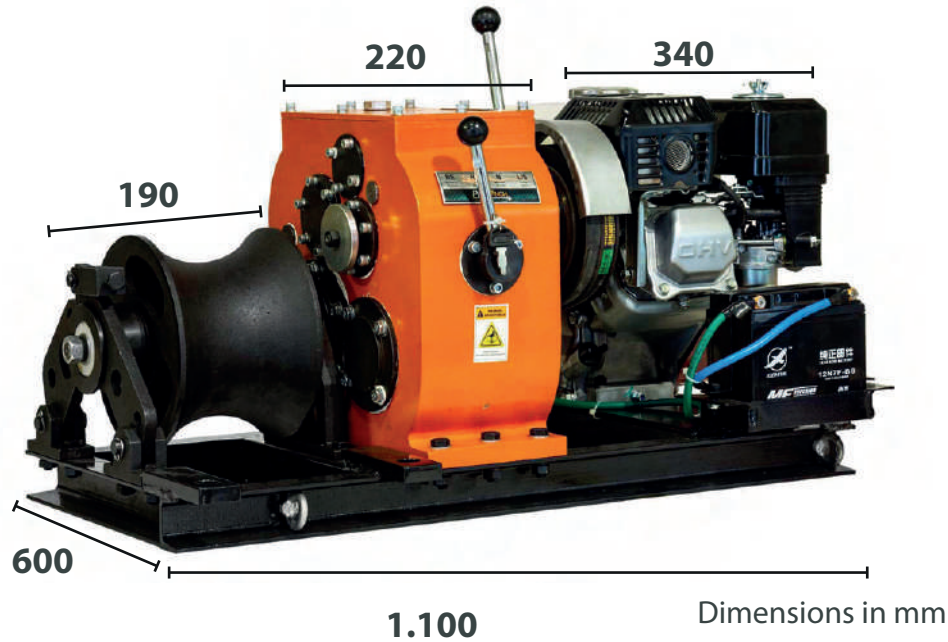

| PARAMETERS | GEAR | | | |
|------------|------|------|------|------|
| | I | | II | |
| | FAST | SLOW | FAST | SLOW |
| CAPACITY | 2,5 | 5 | 0,9 | 1,5 |
| SPEED | 8 | 4 | 24 | 13 |

| CODE | PWCG3T |
|--------------|----------------------|
| CAPACITY | 11.023 Lb |
| SPEED | 13 - 79 Ft / Min |
| MOTOR | Honda GX390 Gasoline |
| TOTAL WEIGHT | 304 Lb |
| TRANSMISSION | Mechanics |
| APPLICATION | Pulling |

WARRANTY 3 GEAR INCLUDED

WINCHE PWCG120

TECHNICAL PARAMETERS

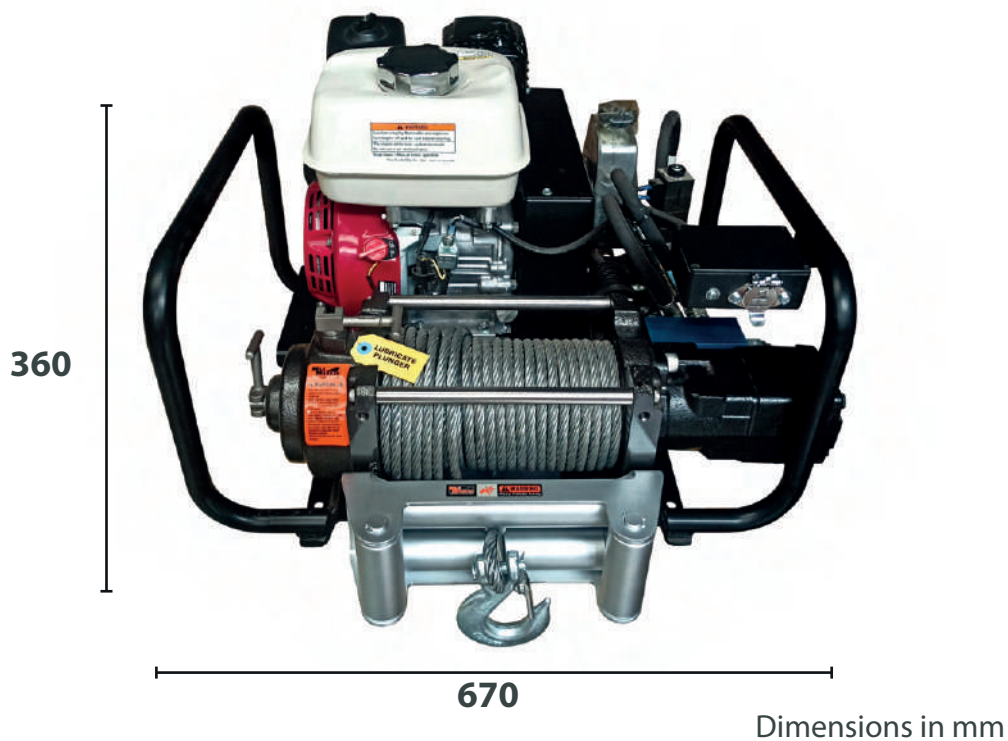

| PARAMETERS | GEAR | | | |
|------------|------|------|------|------|
| | I | | II | |
| | FAST | SLOW | FAST | SLOW |
| CAPACITY | 2,5 | 5 | 0,9 | 1,5 |
| SPEED | 8 | 4 | 24 | 13 |

| CODE | PWCG120 |
|--------------|----------------------|
| APPLICATION | Pulling |
| CAPACITY | 12.000 Lb |
| SPEED | 13 - 66 Ft / Min |
| MOTOR | Honda GX390 Gasoline |
| OIL FLOW | 19 L / min |
| PRESSURE | 1.400 psi |
| IWRC ROPE | 3/8" x 98 ft |
| TOTAL WEIGHT | Pulling |

WARRANTY 3 GEAR INCLUDED



Prowinch Los Angeles
www.Prowinch.com

709 E Gardena Blvd, Carson, CA, 90746.
+1 (800) 971 8061
info@prowinch.com

Cranex Services

4022 East Greenway Road, Suite 11-199,
Phoenix, AZ, 85032.
+1 (602) 321 9751

Fortis Alloy S.A. de C.V

Vicente Guerrero No. 403, Col. San Miguel,
Apodaca, Nuevo Leon, Mexico C.P. 66649.
www.Prowinch.mx
+52 (81) 8244 1351

Contec Industrial

7a Avenida 1-22 Zona 13, Pamplona,
Ciudad de Guatemala, Guatemala.
www.contecindustrial.com/
+502 2381 8383

Prointe S.A DE CV.

Av. Alberto Masferrer Sur, Col. Campestre
No. 211, San Salvador, El Salvador.
+503 2264 1100, +503 2264 2200, +503 2557 5454
www.prointe.com.sv/home/

**PROVINTEC Soluciones de
Ingeniería y Seguridad**

Centro Comercial El Cruce,
Bodega # 7, Coronado,
San Jose, Costa Rica.
www.provinteccr.com/
+506 2229 8000

**HT Automotriz e industrial -
Domingo Diaz**

Ave. José Domingo Díaz, Panamá, Provincia de
Panamá, Panamá.
www.ht.com.pa/
+507 201 8570

DEZA JACOBS

Av Mansiche 1586, Trujillo,
La libertad, Peru.
www.dezajacobs.com
+51 44 618700

Ayers USA Cranes

26111 US-90, Robertsdale, AL 36567.
+1 (251) 929 1773

Prowinch HQ Miami
www.Prowinch.com

2901 NW 21st Terrace, Miami, FL, 33142.
+1 (800) 971 8061
info@prowinch.com

**CONSETI EIRL Consultoría,
Servicio Técnico e Ingeniería**

Avenida Aniana Vargas #5, Plaza Cinco K,
Local B-3, Bonaó, Monseñor Nouel 42000,
República Dominicana.
+1 (809) 710 2529 / +1 (809) 765 6957

Prowinch Colombia

www.Prowinch.co
Calle 15 No 27-74 Local 8,
Barrio Paloquemao, 111411,
Bogotá, Colombia.
+57 601 742 1374
info@prowinch.co

Prowinch Chile
www.Prowinch.cl

Parque Riesco 3407, Recoleta,
Región Metropolitana, Chile.
info@prowinch.cl
+56 22 6218989